

TOSHIBA

FILE NO. 050-200503
(MFR'S VERSION A)

SERVICE MANUAL

COLOR TELEVISION

13A25 13A25C

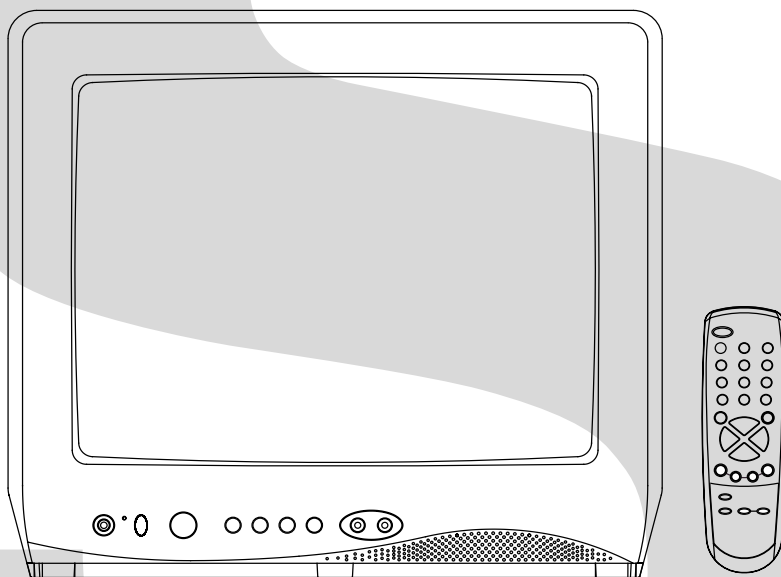

SERVICING NOTICES ON CHECKING

1. KEEP THE NOTICES

As for the places which need special attentions, they are indicated with the labels or seals on the cabinet, chassis and parts. Make sure to keep the indications and notices in the operation manual.

2. AVOID AN ELECTRIC SHOCK

There is a high voltage part inside. Avoid an electric shock while the electric current is flowing.

3. USE THE DESIGNATED PARTS

The parts in this equipment have the specific characters of incombustibility and withstand voltage for safety. Therefore, the part which is replaced should be used the part which has the same character.

Especially as to the important parts for safety which is indicated in the circuit diagram or the table of parts as a  mark, the designated parts must be used.

4. PUT PARTS AND WIRES IN THE ORIGINAL POSITION AFTER ASSEMBLING OR WIRING

There are parts which use the insulation material such as a tube or tape for safety, or which are assembled in the condition that these do not contact with the printed board. The inside wiring is designed not to get closer to the pyrogenic parts and high voltage parts. Therefore, put these parts in the original positions.

5. TAKE CARE TO DEAL WITH THE CATHODE-RAY TUBE

In the condition that an explosion-proof cathode-ray tube is set in this equipment, safety is secured against implosion. However, when removing it or serving from backward, it is dangerous to give a shock. Take enough care to deal with it.

6. AVOID AN X-RAY

Safety is secured against an X-ray by considering about the cathode-ray tube and the high voltage peripheral circuit, etc.

Therefore, when repairing the high voltage peripheral circuit, use the designated parts and make sure not modify the circuit.

Repairing except indicates causes rising of high voltage, and it emits an X-ray from the cathode-ray tube.

7. PERFORM A SAFETY CHECK AFTER SERVICING

Confirm that the screws, parts and wiring which were removed in order to service are put in the original positions, or whether there are the portions which are deteriorated around the serviced places serviced or not. Check the insulation between the antenna terminal or external metal and the AC cord plug blades. And be sure the safety of that.

(INSULATION CHECK PROCEDURE)

1. Unplug the plug from the AC outlet.
2. Remove the antenna terminal on TV and turn on the TV.
3. Insulation resistance between the cord plug terminals and the external exposure metal **[Note 2]** should be more than 1M ohm by using the 500V insulation resistance meter **[Note 1]**.
4. If the insulation resistance is less than 1M ohm, the inspection repair should be required.

[Note 1]

If you have not the 500V insulation resistance meter, use a Tester.

[Note 2]

External exposure metal: Antenna terminal
Headphone jack

HOW TO ORDER PARTS

Please include the following informations when you order parts. (Particularly the VERSION LETTER.)

1. MODEL NUMBER and VERSION LETTER

The MODEL NUMBER can be found on the back of each product and the VERSION LETTER can be found at the end of the SERIAL NUMBER.

2. PART NO. and DESCRIPTION

You can find it in your SERVICE MANUAL.

IMPORTANT

When you exchange IC and Transistor with a heat sink, apply silicon grease on the contact section of the heat sink. Befor applying new silicon grease, remove all the old silicon grease. (Old grease may cause damages to the IC and Transistor.)

ABOUT LEAD FREE SOLDER (PbF)

Distinction of PbF PCB:

PCBs (manufactured) using lead free solder will have a PbF printing on the PCB.
(Please refer to figures.)

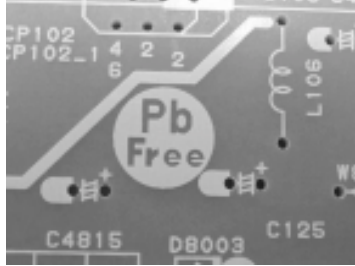

Caution:

- Pb free solder has a higher melting point than standard solder;
Typically the melting point is 50°F~70°F(30°C~40°C) higher.
Please use a soldering iron with temperature control and adjust it to 650°F ± 20°F (350°C ± 10°C).
In case of using high temperature soldering iron, please be carefull not to heat too long.
- Pb free solder will tend to splash when heated too high (about 1100°F/ 600°C).
- All products with the printed circuit board with PbF printing must be serviced with lead free solder.
When soldering or unsoldering, completely remove all of the solder from the pins or solder area,
and be sure to heat the soldering points with the lead free solder until it melts sufficiently.

Recommendations

Recommended lead free solder composition is Sn-3.0Ag-0.5Cu.

TABLE OF CONTENTS

| | |
|-----------------------------------------------------|------------|
| SERVICING NOTICES ON CHECKING | A1-1 |
| HOW TO ORDER PARTS | A1-1 |
| IMPORTANT | A1-1 |
| ABOUT LEAD FREE SOLDER (PbF) | A1-2 |
| TABLE OF CONTENTS | A2-1 |
| GENERAL SPECIFICATIONS | A3-1~A3-10 |
| DISASSEMBLY INSTRUCTIONS | |
| 1.REMOVAL OF ANODE CAP | B1-1 |
| 2.REMOVAL AND INSTALLATION OF FLAT PACKAGE IC | B2-1, B2-2 |
| SERVICE MODE LIST | C-1 |
| CONFIRMATION OF HOURS USED | C-1 |
| WHEN REPLACING EEPROM (MEMORY) IC | C-1 |
| ELECTRICAL ADJUSTMENTS | D-1~D-5 |
| BLOCK DIAGRAM | E-1, E-2 |
| PRINTED CIRCUIT BOARDS | |
| MAIN/CRT | F-1~F-4 |
| SCHEMATIC DIAGRAMS | |
| MICON/CHROMA/TUNER | G-1, G-2 |
| TV POWER | G-3, G-4 |
| DEFLECTION/CRT | G-5, G-6 |
| SOUND/AV | G-7, G-8 |
| WAVEFORMS | H-1, H-2 |
| MECHANICAL EXPLODED VIEW | I-1, I-2 |
| MECHANICAL REPLACEMENT PARTS LIST | J1-1, J1-2 |
| ELECTRICAL REPLACEMENT PARTS LIST | J2-1~ J2-6 |

GENERAL SPECIFICATIONS

| | | | | | |
|------------|---------------------------|------------------------|---------------------------|-------------------------------------------------|----------------------------------------------------------------|
| G-1 | TV System | CRT | CRT Size / Visual Size | 13 inch / 335.4mmV | |
| | | | CRT Type | Normal | |
| | | | Deflection | 90 degree | |
| | | | Magnetic Field BV/BH | +0.45G/0.18G | |
| | | | Color System | NTSC | |
| | | | Speaker | 1Speaker | |
| | | | | Position | Bottom |
| | | | | Size | 3 Inch |
| | | | | Impedance | 8 ohm |
| | | | Sound Output | MAX | 1.0 W |
| | | 10%(Typical) | 0.8 W | | |
| | | NTSC3.58+4.43 /PAL60Hz | No | | |
| G-2 | Tuning System | Broadcasting System | | US System M | |
| | | Tuner and Receive CH | System | 1Tuner | |
| | | | Destination | USA(W/ CATV) | |
| | | | Tuning System | F-Synth | |
| | | | Input Impedance | VHF/UHF 75 ohm | |
| | | | CH Coverage | 2 - 69, 4A, A-5 - A-1, A - I, J - W, W+1 - W+84 | |
| | | Intermediate Frequency | Picture(FP) | 45.75MHz | |
| | | | Sound(FS) | 41.25MHz | |
| | | | FP-FS | 4.50MHz | |
| | | | Preset CH | No | |
| | Stereo/Dual TV Sound | No | | | |
| | Tuner Sound Muting | Yes | | | |
| G-3 | Power | Power Source | AC | 120V AC 60Hz | |
| | | | DC | | |
| | | Power Consumption | | at AC | |
| | | | Stand by (at AC) Per Year | | 54 W at AC 120 V 60 Hz 5 W at AC 120 V 60 Hz -- kWh/Year |
| | Protector | Power Fuse | Yes | | |
| G-4 | Regulation | Safety | | UL | |
| | | Radiation | | FCC | |
| | | X-Radiation | | DHHS | |
| G-5 | Temperature | Operation | | +5oC ~ +40oC | |
| | | Storage | | -20oC ~ +60oC | |
| G-6 | Operating Humidity | | | Less than 80% RH | |

GENERAL SPECIFICATIONS

| | | | | | |
|-----|-----------------------------------|-------------------------|------------------------|----------------------|-----|
| G-7 | On Screen Display | Menu | | Yes | |
| | | Menu Type | | Character | |
| | | Picture | | Yes | |
| | | | | Contrast | Yes |
| | | | | Brightness | Yes |
| | | | | Color | Yes |
| | | | | Tint | Yes |
| | | | | Sharpness | Yes |
| | | | Audio | | No |
| | | | | Bass | No |
| | | | | Treble | No |
| | | | | Balance | No |
| | | | | BBE On/Off | No |
| | | | | Stable Sound On/Off | No |
| | | | CH Set Up | | Yes |
| | | | | TV/CABLE(CATV) | Yes |
| | | | | Auto CH Memory | Yes |
| | | | | Add/ Delete | Yes |
| | | | Language | | Yes |
| | | | V-chip | | Yes |
| | | | Lock | | Yes |
| | | | On Timer | | Yes |
| | | | | CH Label | No |
| | | | | Favorite CH | No |
| | | | | Color Stream DVD/DTV | No |
| | | | Control Level | | Yes |
| | | | | Volume | Yes |
| | | | | Brightness | Yes |
| | | | | Contrast | Yes |
| | | | | Color | Yes |
| | | | | Tint | Yes |
| | | | | Sharpness | Yes |
| | | | | Tuning | No |
| | | Bass | No | | |
| | | Treble | No | | |
| | | Balance | No | | |
| | | Back Light | No | | |
| | | Stereo,Audio Output,SAP | No | | |
| | Video | | Yes | | |
| | Color Stream | | No | | |
| | Channel(TV/Cable) | | Yes | | |
| | CH Label | | No | | |
| | Game Timer | | Yes | | |
| | Sleep Timer | | Yes | | |
| | Sound Mute | | Yes | | |
| | V-chip Rating | | Yes | | |
| G-8 | OSD Language | | English French Spanish | | |
| G-9 | Clock and Timer | Sleep Timer | Max Time | 120 Min | |
| | | | Step | 10 Min | |
| | | On Timer | Program(On Timer) | Yes | |
| | | Wake Up Timer | | No | |
| | Timer Back-up (at Power Off Mode) | more than | -- Min Sec | | |

GENERAL SPECIFICATIONS

| | | | | |
|-------------|-----------------------|----------------------|-------------------------------|--------------------|
| G-10 | Remote Control | Unit | RC-EH | |
| | | Glow in Dark Remocon | Yes | |
| | | Format | Toshiba | |
| | | Custom Code | <u>40-BF h</u> | |
| | | Power Source | Voltage(D.C) UM size x pcs | 3V UM-4 x 2 pcs |
| | | Total Keys | | <u>27</u> Keys |
| | | Keys | Power | Yes |
| | | | 1 | Yes |
| | | | 2 | Yes |
| | | | 3 | Yes |
| | | | 4 | Yes |
| | | | 5 | Yes |
| | | | 6 | Yes |
| | | | 7 | Yes |
| | | | 8 | Yes |
| | | | 9 | Yes |
| | | | 0 | Yes |
| | | | 100 | No |
| | | | CH Up | Yes |
| | | | CH Down | Yes |
| | | | Volume Up | Yes |
| | | | Volume Down | Yes |
| | | | TV/Caption/Text | Yes |
| | | | CH1/CH2 | Yes |
| | | | TV/Video(TV/AV) | Yes |
| | | | CH RTN/CH ENT(Quick View) | Yes |
| | | | Sleep | Yes |
| | | | RE Call(Call) | Yes |
| | | | Reset | Yes |
| | | | Menu | Yes |
| | | | Enter | Yes |
| | | | Mute | Yes |
| | | | Exit | No |
| | | | MTS(Audio Select) | No |
| | | | Set + | Yes |
| | | | Set - | Yes |
| | | | Multi Brand Keys | |
| | | | CH Up(VCR) | No |
| | | | CH Down(VCR) | No |
| | | | Pause/Still | No |
| | TV/VCR(VCR) | No | | |
| | Code | No | | |
| | FF | No | | |
| | Rew | No | | |
| | Rec | No | | |
| | Play | No | | |
| | Stop | No | | |
| | TV | No | | |
| | VCR | No | | |
| | Cable | No | | |

GENERAL SPECIFICATIONS

| | | | | |
|-----------------------------------|--------------------|-------------------------------|---------------------------|-----------------------------------|
| G-11 | Features | Auto Degauss | Yes | |
| | | Auto Shut Off | Yes | |
| | | Canal+ | No | |
| | | CATV | Yes | |
| | | Anti-theft | No | |
| | | Rental | No | |
| | | Memory(Last CH) | Yes | |
| | | Memory(Last Volume) | Yes | |
| | | V-Chip | Yes | |
| | | | Type | USA,ORION Type |
| | | BBE | No | |
| | | Auto Search | No | |
| | | CH Allocation | No | |
| | | SAP | No | |
| | | Channel Lock | No | |
| | | Just Clock Function | No | |
| | | Game Position | No | |
| | | CH Label | No | |
| | | VM Circuit | No | |
| | | Full OSD | No | |
| | | Premiere | No | |
| | | Comb Filter | No | |
| | | | Lines | |
| | | Auto CH Memory | Yes | |
| | | Hotel Lock | No | |
| | | Closed Caption | Yes | |
| | | FBT Leak Test Protect | Yes | |
| | | CH Lock | Yes | |
| | | Video Lock | Yes | |
| | | Game Timer (Max Time:120 Min) | Yes | |
| | | Stable Sound | No | |
| | | Energy Star | No | |
| Power On Memory | Yes | | | |
| Favorite CH | No | | | |
| G-12 | Accessories | Owner's Manual | Language w/Guarantee Card | English/Spanish[From '04 DEC O/R] |
| | | Remote Control Unit | | Yes |
| | | Rod Antenna | | No |
| | | | Poles | |
| | | | Terminal | |
| | | Loop Antenna | | No |
| | | | Terminal | - |
| | | U/V Mixer | | No |
| | | DC Car Cord (Center+) | | No |
| | | Guarantee Card | | No |
| | | Warning Sheet | | No |
| | | Circuit Diagram | | No |
| | | Antenna Change Plug | | No |
| | | Service Facility List | | No |
| | | Important Safeguard | | No |
| | | Dew/AHC Caution Sheet | | No |
| | | AC Plug Adapter | | No |
| | | Quick Set-up Sheet | | No |
| | | Battery | | Yes |
| | | | UM size x pcs | UM-4 x 2 pcs |
| | | | OEM Brand | No |
| | | AC Cord | | No |
| AV Cord (2Pin-1Pin) | | No | | |
| Registration Card (NDL Card) | | Yes | | |
| ESP Card | | No | | |
| 300 ohm to 75 ohm Antenna Adapter | | No | | |

GENERAL SPECIFICATIONS

| | | | | | |
|-----------------------|-------------------------|-------------------------------|-----------------------------------------------------|----------------------------|-----------|
| G-13 | Interface | Switch | Front | Power | Yes |
| | | | | System Select | No |
| | | | | Main Power SW | No |
| | | | | Sub Power | No |
| | | | | Channel Up/Reset | Yes |
| | | | | Channel Down/Enter | Yes |
| | | | | Volume Up/Set Up | Yes |
| | | | | Volume Down/Set Down | Yes |
| | | | | MENU=Volume Up+Volume Down | Yes |
| | | | | Rear | AC/DC |
| | | TV/CATV Selector | No | | |
| | | Degauss | No | | |
| | | Main Power SW | No | | |
| | | Indicator | Power | Yes | |
| | | | Stand-by | No | |
| | | | On Timer | No | |
| | | Terminals | Front | Video Input | RCA |
| | | | | Audio Input | RCA x 1 |
| | | | | Other Terminal | Ear Phone |
| | | | Rear | Video Input(Rear1) | No |
| | | | | Video Input(Rear2) | No |
| | | | | Audio Input(Rear1) | No |
| | | | | Audio Input(Rear2) | No |
| | | | | Video Output | No |
| Audio Output | No | | | | |
| Euro Scart | No | | | | |
| Color Stream | No | | | | |
| Diversity | No | | | | |
| Ext Speaker | No | | | | |
| DC Jack 12V(Center +) | No | | | | |
| VHF/UHF Antenna Input | F Type | | | | |
| AC Outlet | No | | | | |
| G-14 | Set Size | | | Approx. W x D x H (mm) | |
| G-15 | Weight | Net (Approx.) | | <u>9.5 kg (20.9 lbs)</u> | |
| | | Gross (Approx.) | | <u>11.0kg (24.4lbs)</u> | |
| G-16 | Carton | Master Carton | | No | |
| | | | Content | --- Sets | |
| | | | Material | -- /-- | |
| | | | Dimensions W x D x H(mm) | <u>-- x -- x --</u> | |
| | | Description of Origin | | No | |
| | | Gift Box | | Yes | |
| | | | Material | Double/Brown | |
| | | | Dimensions W x D x H(mm) | <u>440 x 408 x 380</u> | |
| | | | Design | As per Buyer's | |
| | | Description of Origin | | Yes | |
| | | Drop Test | Natural Dropping At 1 Corner / 3 Edges / 6 Surfaces | | |
| | | | Height (cm) | 62 | |
| Container Stuffing | | <u>866</u> Sets/40' container | | | |
| G-17 | Cabinet Material | Cabinet | Cabinet Front | PS 94V0 DECABROM | |
| | | | Cabinet Rear | PS 94V0 DECABROM | |
| | | PCB | Non-Halogen Demand | No | |
| | | | Eyelet Demand | Yes | |
| G-18 | Environment | Pb Free | Phase3 | | |

GENERAL SPECIFICATIONS

| | | | | | |
|------------|---------------------------|------------------------|---------------------------|--------------------|----------------------------------------------------------------|
| G-1 | TV System | CRT | CRT Size / Visual Size | 13 inch / 335.4mmV | |
| | | | CRT Type | Normal | |
| | | | Deflection | 90 degree | |
| | | | Magnetic Field BV/BH | +0.45G/0.18G | |
| | | | Color System | NTSC | |
| | | | Speaker | 1Speaker | |
| | | | | Position | Bottom |
| | | | | Size | 3 Inch |
| | | | | Impedance | 8 ohm |
| | | | Sound Output | MAX | 1.0 W |
| | | 10%(Typical) | 0.8 W | | |
| | | NTSC3.58+4.43 /PAL60Hz | No | | |
| G-2 | Tuning System | Broadcasting System | | US System M | |
| | | Tuner and Receive CH | System | 1Tuner | |
| | | | Destination | USA(W/ CATV) | |
| | | | Tuning System | F-Synth | |
| | | | Input Impedance | VHF/UHF 75 ohm | |
| | | | | CH Coverage | 2 - 69, 4A, A-5 - A-1, A - I, J - W, W+1 - W+84 |
| | | | Intermediate Frequency | Picture(FP) | 45.75MHz |
| | | | | Sound(FS) | 41.25MHz |
| | | | | FP-FS | 4.50MHz |
| | | | Preset CH | | No |
| | Stereo/Dual TV Sound | | No | | |
| | Tuner Sound Muting | | Yes | | |
| G-3 | Power | Power Source | AC | 120V AC 60Hz | |
| | | | DC | | |
| | | Power Consumption | | at AC | |
| | | | Stand by (at AC) Per Year | | 54 W at AC 120 V 60 Hz 5 W at AC 120 V 60 Hz -- kWh/Year |
| | Protector | Power Fuse | Yes | | |
| G-4 | Regulation | Safety | | CSA | |
| | | Radiation | | IC | |
| | | X-Radiation | | HWC | |
| G-5 | Temperature | Operation | | +5oC ~ +40oC | |
| | | Storage | | -20oC ~ +60oC | |
| G-6 | Operating Humidity | | | Less than 80% RH | |

GENERAL SPECIFICATIONS

| | | | | | |
|-----|-----------------------------------|---------------|----------------------|-----------|---------|
| G-7 | On Screen Display | Menu | | Yes | |
| | | Menu Type | | Character | |
| | | Picture | | Yes | |
| | | | Contrast | | Yes |
| | | | Brightness | | Yes |
| | | | Color | | Yes |
| | | | Tint | | Yes |
| | | | Sharpness | | Yes |
| | | | Audio | | No |
| | | | Bass | | No |
| | | | Treble | | No |
| | | | Balance | | No |
| | | | BBE On/Off | | No |
| | | | Stable Sound On/Off | | No |
| | | | CH Set Up | | Yes |
| | | | TV/CABLE(CATV) | | Yes |
| | | | Auto CH Memory | | Yes |
| | | | Add/ Delete | | Yes |
| | | | Language | | Yes |
| | | | V-chip | | No |
| | | | Lock | | Yes |
| | | | On Timer | | Yes |
| | | | CH Label | | No |
| | | | Favorite CH | | No |
| | | | Color Stream DVD/DTV | | No |
| | | | Control Level | | Yes |
| | | | Volume | | Yes |
| | | | Brightness | | Yes |
| | | | Contrast | | Yes |
| | | | Color | | Yes |
| | | | Tint | | Yes |
| | | | Sharpness | | Yes |
| | | | Tuning | | No |
| | Bass | | No | | |
| | Treble | | No | | |
| | Balance | | No | | |
| | Back Light | | No | | |
| | Stereo,Audio Output,SAP | | No | | |
| | Video | | Yes | | |
| | Color Stream | | No | | |
| | Channel(TV/Cable) | | Yes | | |
| | CH Label | | No | | |
| | Game Timer | | Yes | | |
| | Sleep Timer | | Yes | | |
| | Sound Mute | | Yes | | |
| | V-chip Rating | | No | | |
| G-8 | OSD Language | | English | French | Spanish |
| G-9 | Clock and Timer | Sleep Timer | Max Time | 120 Min | |
| | | | Step | 10 Min | |
| | | On Timer | Program(On Timer) | Yes | |
| | | Wake Up Timer | | No | |
| | Timer Back-up (at Power Off Mode) | more than | -- | Min | Sec |

GENERAL SPECIFICATIONS

| | | | | |
|-------------|-----------------------|----------------------|-------------------------------|--------------------|
| G-10 | Remote Control | Unit | RC-EH | |
| | | Glow in Dark Remocon | Yes | |
| | | Format | Toshiba | |
| | | Custom Code | 40-BF h | |
| | | Power Source | Voltage(D.C) UM size x pcs | 3V UM-4 x 2 pcs |
| | | Total Keys | | 27 Keys |
| | | Keys | Power | Yes |
| | | | 1 | Yes |
| | | | 2 | Yes |
| | | | 3 | Yes |
| | | | 4 | Yes |
| | | | 5 | Yes |
| | | | 6 | Yes |
| | | | 7 | Yes |
| | | | 8 | Yes |
| | | | 9 | Yes |
| | | | 0 | Yes |
| | | | 100 | No |
| | | | CH Up | Yes |
| | | | CH Down | Yes |
| | | | Volume Up | Yes |
| | | | Volume Down | Yes |
| | | | TV/Caption/Text | Yes |
| | | | CH1/CH2 | Yes |
| | | | TV/Video(TV/AV) | Yes |
| | | | CH RTN/CH ENT(Quick View) | Yes |
| | | | Sleep | Yes |
| | | | RE Call(Call) | Yes |
| | | | Reset | Yes |
| | | | Menu | Yes |
| | | | Enter | Yes |
| | | | Mute | Yes |
| | | | Exit | No |
| | | | MTS(Audio Select) | No |
| | | | Set + | Yes |
| | | | Set - | Yes |
| | | | Multi Brand Keys | |
| | | | CH Up(VCR) | No |
| | | | CH Down(VCR) | No |
| | | | Pause/Still | No |
| | TV/VCR(VCR) | No | | |
| | Code | No | | |
| | FF | No | | |
| | Rew | No | | |
| | Rec | No | | |
| | Play | No | | |
| | Stop | No | | |
| | TV | No | | |
| | VCR | No | | |
| | Cable | No | | |

GENERAL SPECIFICATIONS

| | | | |
|-----------------------------------|--------------------|-------------------------------|---------------------------|
| G-11 | Features | Auto Degauss | Yes |
| | | Auto Shut Off | Yes |
| | | Canal+ | No |
| | | CATV | Yes |
| | | Anti-theft | No |
| | | Rental | No |
| | | Memory(Last CH) | Yes |
| | | Memory(Last Volume) | Yes |
| | | V-Chip | No |
| | | Type | |
| | | BBE | No |
| | | Auto Search | No |
| | | CH Allocation | No |
| | | SAP | No |
| | | Channel Lock | No |
| | | Just Clock Function | No |
| | | Game Position | No |
| | | CH Label | No |
| | | VM Circuit | No |
| | | Full OSD | No |
| | | Premiere | No |
| | | Comb Filter | No |
| | | Lines | |
| | | Auto CH Memory | Yes |
| | | Hotel Lock | No |
| | | Closed Caption | Yes |
| | | FBT Leak Test Protect | Yes |
| | | CH Lock | Yes |
| | | Video Lock | Yes |
| | | Game Timer (Max Time:120 Min) | Yes |
| | | Stable Sound | No |
| | | Energy Star | No |
| | | Power On Memory | Yes |
| Favorite CH | No | | |
| G-12 | Accessories | Owner's Manual | Language w/Guarantee Card |
| | | | English/French |
| | | Remote Control Unit | Yes |
| | | Rod Antenna | No |
| | | Poles | |
| | | Terminal | |
| | | Loop Antenna | No |
| | | Terminal | - |
| | | U/V Mixer | No |
| | | DC Car Cord (Center+) | No |
| | | Guarantee Card | No |
| | | Warning Sheet | No |
| | | Circuit Diagram | No |
| | | Antenna Change Plug | No |
| | | Service Facility List | No |
| | | Important Safeguard | No |
| | | Dew/AHC Caution Sheet | No |
| | | AC Plug Adapter | No |
| | | Quick Set-up Sheet | No |
| | | Battery | Yes |
| | | UM size x pcs | UM-4 x 2 pcs |
| | | OEM Brand | No |
| | | AC Cord | No |
| AV Cord (2Pin-1Pin) | No | | |
| Registration Card (NDL Card) | No | | |
| ESP Card | No | | |
| 300 ohm to 75 ohm Antenna Adapter | No | | |

GENERAL SPECIFICATIONS

| | | | | | |
|-----------------------|-------------------------|-------------------|--------------------------|-----------------------------------------------------|-----------|
| G-13 | Interface | Switch | Front | Power | Yes |
| | | | | System Select | No |
| | | | | Main Power SW | No |
| | | | | Sub Power | No |
| | | | | Channel Up/Reset | Yes |
| | | | | Channel Down/Enter | Yes |
| | | | | Volume Up/Set Up | Yes |
| | | | | Volume Down/Set Down | Yes |
| | | | | MENU=Volume Up+Volume Down | Yes |
| | | | | Rear | AC/DC |
| | | TV/CATV Selector | No | | |
| | | Degauss | No | | |
| | | Main Power SW | No | | |
| | | Indicator | Power | Yes | |
| | | | Stand-by | No | |
| | | | On Timer | No | |
| | | Terminals | Front | Video Input | RCA |
| | | | | Audio Input | RCA x 1 |
| | | | | Other Terminal | Ear Phone |
| | | | Rear | Video Input(Rear1) | No |
| | | | | Video Input(Rear2) | No |
| | | | | Audio Input(Rear1) | No |
| | | | | Audio Input(Rear2) | No |
| Video Output | No | | | | |
| Audio Output | No | | | | |
| Euro Scart | No | | | | |
| Color Stream | No | | | | |
| Diversity | No | | | | |
| Ext Speaker | No | | | | |
| DC Jack 12V(Center +) | No | | | | |
| VHF/UHF Antenna Input | F Type | | | | |
| AC Outlet | No | | | | |
| G-14 | Set Size | | | Approx. W x D x H (mm) | |
| G-15 | Weight | Net (Approx.) | | <u>9.5 kg (20.9 lbs)</u> | |
| | | Gross (Approx.) | | <u>11.0kg (24.4lbs)</u> | |
| G-16 | Carton | Master Carton | | No | |
| | | | Content | --- Sets | |
| | | | Material | -- /-- | |
| | | | Dimensions W x D x H(mm) | <u>-- x -- x --</u> | |
| | | | Description of Origin | No | |
| | | Gift Box | | Yes | |
| | | | Material | Double/Brown | |
| | | | Dimensions W x D x H(mm) | <u>440 x 408 x 380</u> | |
| | | | Design | As per Buyer's | |
| | | | Description of Origin | Yes | |
| | | Drop Test | | Natural Dropping At 1 Corner / 3 Edges / 6 Surfaces | |
| | | | Height (cm) | 62 | |
| | | | Container Stuffing | <u>866</u> Sets/40' container | |
| G-17 | Cabinet Material | Cabinet | Cabinet Front | PS 94V0 DECABROM | |
| | | | Cabinet Rear | PS 94V0 DECABROM | |
| | | PCB | Non-Halogen Demand | No | |
| | | | Eyelet Demand | Yes | |
| | | | | Yes | |
| G-18 | Environment | Pb-free Soldering | Yes | | |
| | | Parts Specificat | Yes | | |

DISASSEMBLY INSTRUCTIONS

1. REMOVAL OF ANODE CAP

Read the following **NOTED** items before starting work.

- * After turning the power off there might still be a potential voltage that is very dangerous. When removing the Anode Cap, make sure to discharge the Anode Cap's potential voltage.
- * Do not use pliers to loosen or tighten the Anode Cap terminal, this may cause the spring to be damaged.

REMOVAL

1. Follow the steps as follows to discharge the Anode Cap. (Refer to Fig. 1-1.)

Connect one end of an Alligator Clip to the metal part of a flat-blade screwdriver and the other end to ground. While holding the plastic part of the insulated Screwdriver, touch the support of the Anode with the tip of the Screwdriver. A cracking noise will be heard as the voltage is discharged.

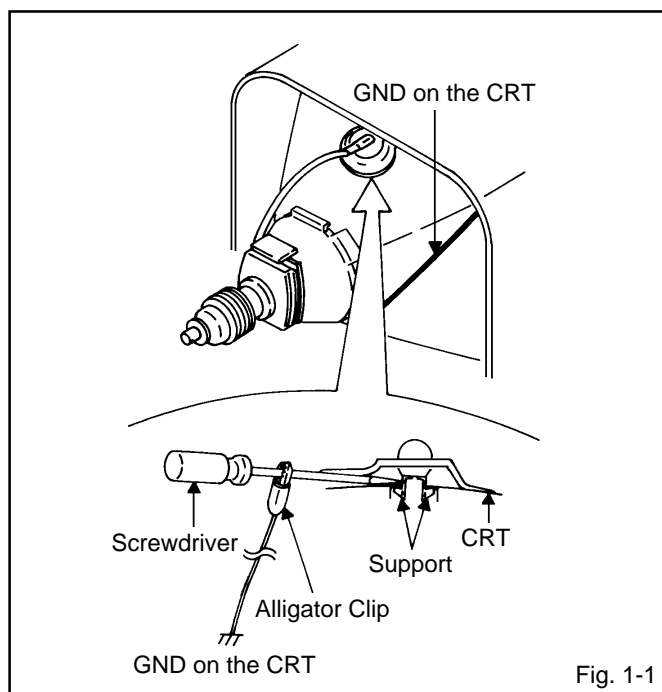

2. Flip up the sides of the Rubber Cap in the direction of the arrow and remove one side of the support. (Refer to Fig. 1-2.)

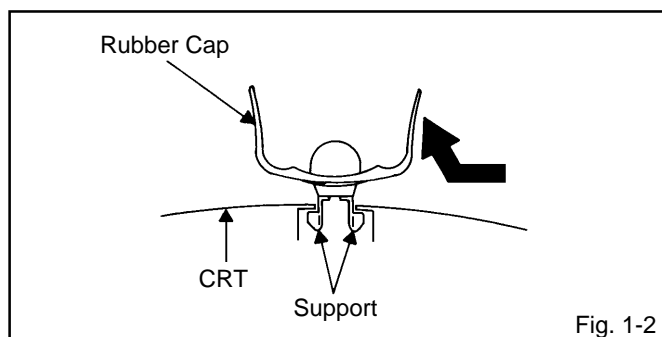

3. After one side is removed, pull in the opposite direction to remove the other.

NOTE

Take care not to damage the Rubber Cap.

INSTALLATION

1. Clean the spot where the cap was located with a small amount of alcohol. (Refer to Fig. 1-3.)

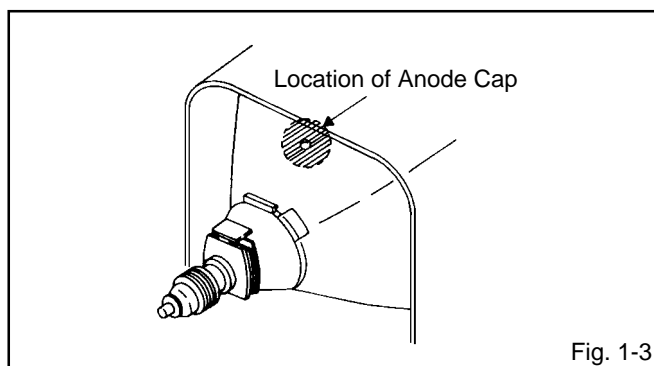

NOTE

Confirm that there is no dirt, dust, etc. at the spot where the cap was located.

2. Arrange the wire of the Anode Cap and make sure the wire is not twisted.
3. Turn over the Rubber Cap. (Refer to Fig. 1-4.)

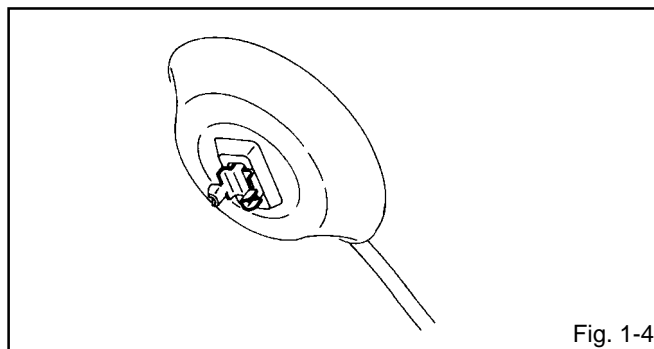

4. Insert one end of the Anode Support into the anode button, then the other as shown in Fig. 1-5.

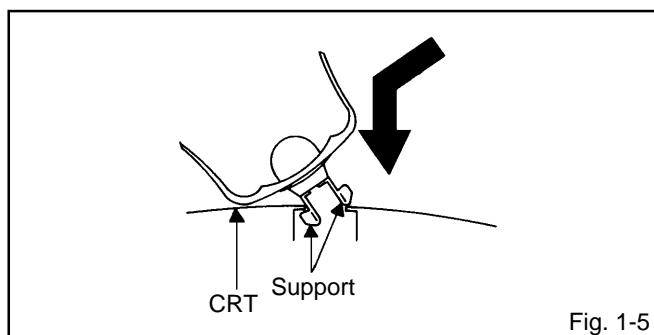

5. Confirm that the Support is securely connected.
6. Put on the Rubber Cap without moving any parts.

DISASSEMBLY INSTRUCTIONS

2. REMOVAL AND INSTALLATION OF FLAT PACKAGE IC

REMOVAL

1. Put Masking Tape (cotton tape) around the Flat Package IC to protect other parts from any damage. (Refer to Fig. 2-1.)

NOTE

Masking is carried out on all the parts located within 10 mm distance from IC leads.

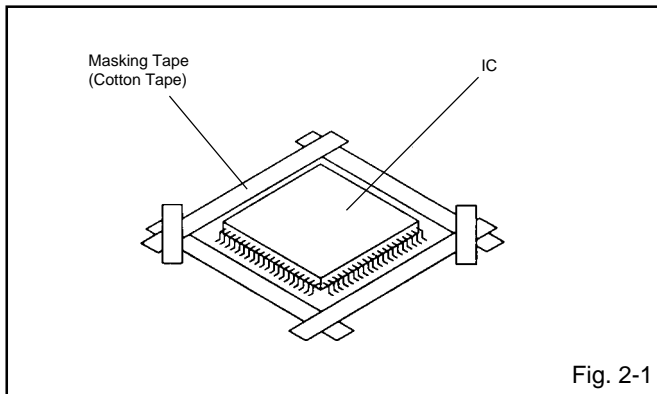

2. Heat the IC leads using a blower type IC desoldering machine. (Refer to Fig. 2-2.)

NOTE

Do not rotate or move the IC back and forth, until IC can move back and forth easily after desoldering the leads completely.

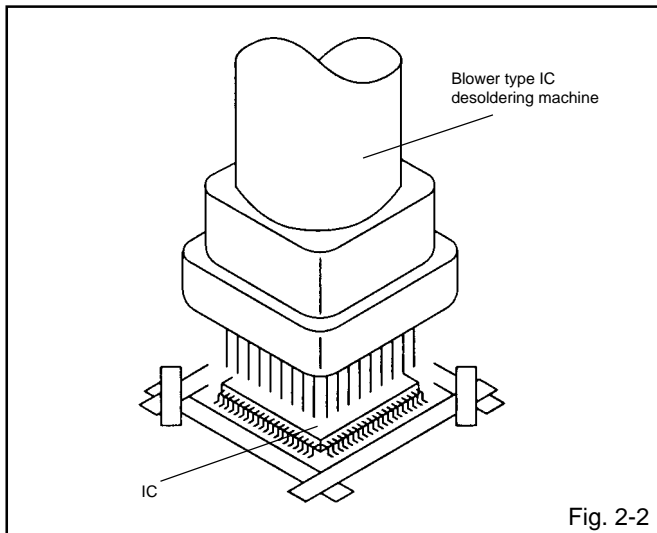

3. When IC starts moving back and forth easily after desoldering completely, pickup the corner of the IC using a tweezers and remove the IC by moving with the IC desoldering machine. (Refer to Fig. 2-3.)

NOTE

Some ICs on the PCB are affixed with glue, so be careful not to break or damage the foil of each IC leads or solder lands under the IC when removing it.

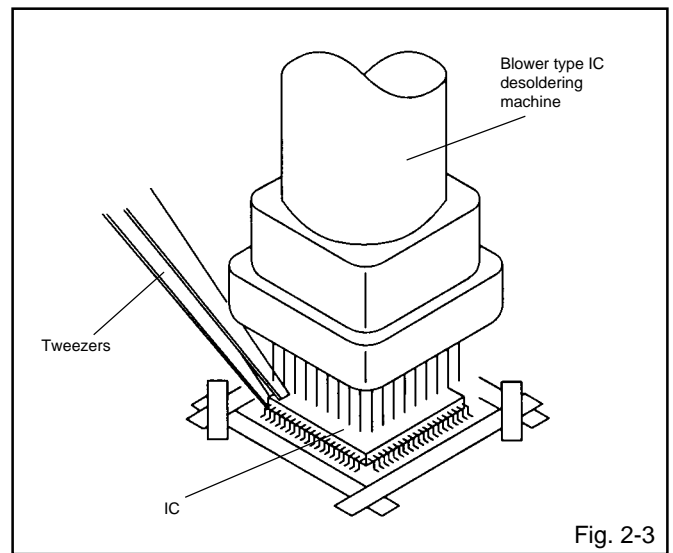

4. Peel off the Masking Tape.

5. Absorb the solder left on the pattern using the Braided Shield Wire. (Refer to Fig. 2-4.)

NOTE

Do not move the Braided Shield Wire in the vertical direction towards the IC pattern.

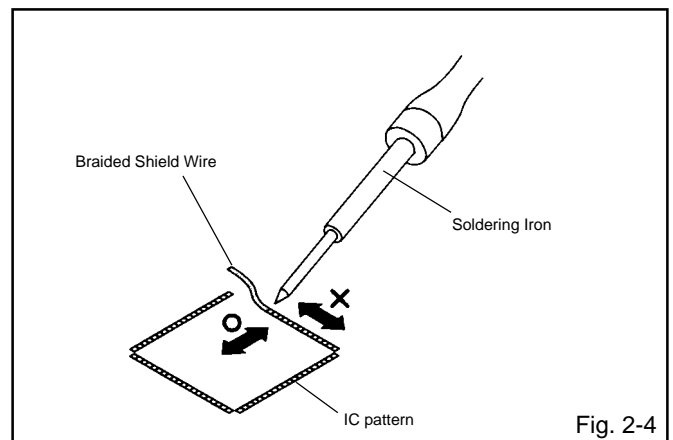

DISASSEMBLY INSTRUCTIONS

INSTALLATION

1. Take care of the polarity of new IC and then install the new IC fitting on the printed circuit pattern. Then solder each lead on the diagonal positions of IC temporarily. (Refer to Fig. 2-5.)

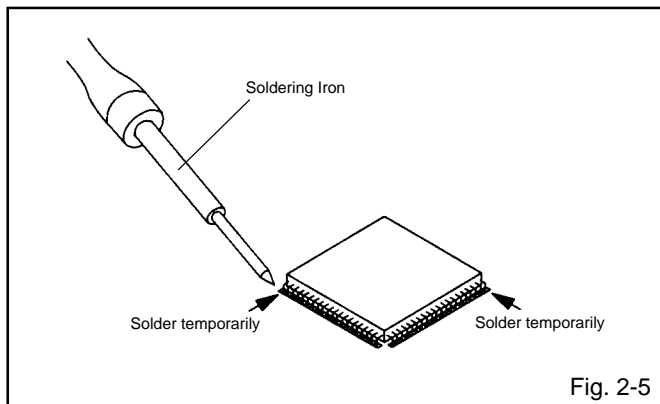

2. Supply the solder from the upper position of IC leads sliding to the lower position of the IC leads. (Refer to Fig. 2-6.)

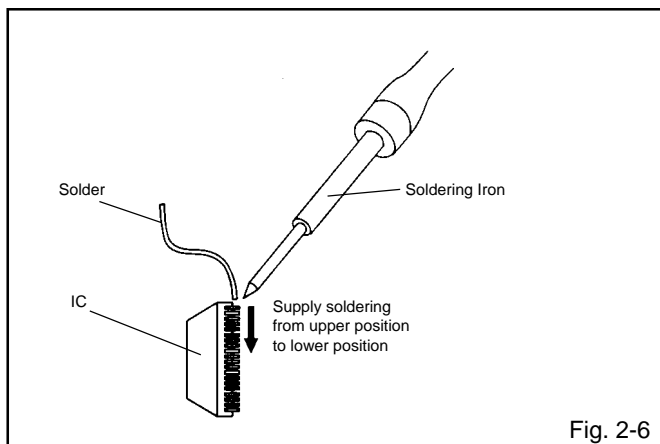

3. Absorb the solder left on the lead using the Braided Shield Wire. (Refer to Fig. 2-7.)

NOTE

Do not absorb the solder to excess.

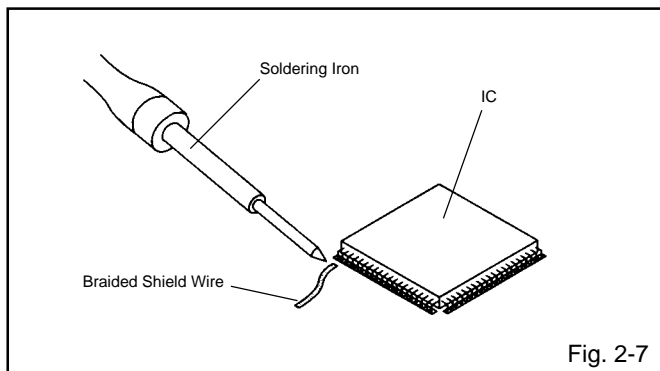

4. When bridge-soldering between terminals and/or the soldering amount are not enough, resolder using a Thin-tip Soldering Iron. (Refer to Fig. 2-8.)

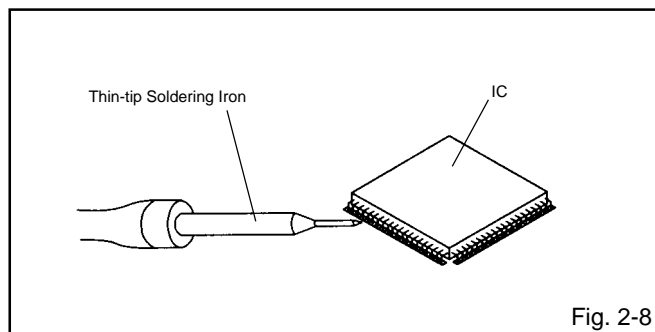

5. Finally, confirm the soldering status on four sides of the IC using a magnifying glass. Confirm that no abnormality is found on the soldering position and installation position of the parts around the IC. If some abnormality is found, correct by resoldering.

NOTE

When the IC leads are bent during soldering and/or repairing, do not repair the bending of leads. If the bending of leads are repaired, the pattern may be damaged. So, always be sure to replace the IC in this case.

SERVICE MODE LIST

This unit is provided with the following SERVICE MODES so you can repair, examine and adjust easily. To enter to the Service Mode, press both set key and remote control key for more than 2 seconds.

| Set Key | Remocon Key | Operations |
|--------------|-------------|-------------------------------------------------------------------------------------------------------------------------------------------------------------------------------------------------------------|
| VOL. (-) MIN | 0 | Releasing of V-CHIP PASSWORD. |
| VOL. (-) MIN | 1 | Initialization of factory data. NOTE: Do not use this for normal servicing. If you set factory initialization, the memories are reset such as the channel setting, and the POWER ON total hours. |
| VOL. (-) MIN | 6 | POWER ON total hours is displayed on the screen. Refer to the "CONFIRMATION OF HOURS USED". Can be checked of the INITIAL DATA of MEMORY IC. Refer to the "WHEN REPLACING EEPROM (MEMORY) IC". |
| VOL. (-) MIN | 9 | Display of the Adjustment MENU on the screen. Refer to the "ELECTRICAL ADJUSTMENT" (On-Screen Display Adjustment). |

CONFIRMATION OF HOURS USED

POWER ON total hours can be checked on the screen. Total hours are displayed in 16 system of notation.

NOTE: If you set factory initialization, the total hours is reset to "0".

1. Set the VOLUME to minimum.
2. Press both VOL. DOWN button on the set and Channel button **(6)** on the remote control for more than 2 seconds.
3. After the confirmation of using hours, turn off the power.

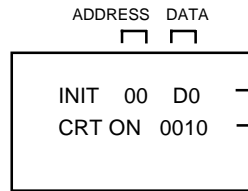

Initial setting content of MEMORY IC.
POWER ON total hours.
= (16 x 16 x 16 x thousands digit value)
+ (16 x 16 x hundreds digit value)
+ (16 x tens digit value)
+ (ones digit value)

FIG. 1

WHEN REPLACING EEPROM (MEMORY) IC

If a service repair is undertaken where it has been required to change the MEMORY IC, the following steps should be taken to ensure correct data settings while making reference to TABLE 1.

| INI | +0 | +1 | +2 | +3 | +4 | +5 | +6 | +7 | +8 | +9 | +A | +B | +C | +D | +E | +F |
|-----|----|----|----|----|----|----|----|----|----|----|----|----|----|----|----|----|
| 00 | D0 | 04 | EB | 4E | 47 | B3 | 24 | 69 | *1 | 00 | 00 | 05 | 90 | D6 | 00 | 07 |

*1

| INI | USA | CANADA |
|-----|-----|--------|
| 08 | 39 | 38 |

Table 1

1. Enter DATA SET mode by setting VOLUME to minimum.
2. While holding down VOLUME button on front cabinet, press key **(6)** on remote control for more than 2 seconds. ADDRESS and DATA should appear as FIG 1.
3. ADDRESS is now selected and should "blink". Using the VOL. +/- button on the remote, step through the ADDRESS until required ADDRESS to be changed is reached.
4. Press ENTER to select DATA. When DATA is selected, it will "blink".
5. Again, step through the DATA using VOL. +/- button until required DATA value has been selected.
6. Pressing ENTER will take you back to ADDRESS for further selection if necessary.
7. Repeat steps 3 to 6 until all data has been checked.
8. When satisfied correct DATA has been entered, turn POWER off (return to STANDBY MODE) to finish DATA input.

After the data input, set to the initializing of shipping.

9. Turn POWER on.
 10. While holding down VOLUME button on front cabinet, press key **(1)** on remote control for more than 2 seconds.
 11. After the finishing of the initializing of shipping, the unit will turn off automatically.
- The unit will now have the correct DATA for the new MEMORY IC.

ELECTRICAL ADJUSTMENTS

1. BEFORE MAKING ELECTRICAL ADJUSTMENTS

Read and perform these adjustments when repairing the circuits or replacing electrical parts or PCB assemblies.

CAUTION

- Use an isolation transformer when performing any service on this chassis.
- Before removing the anode cap, discharge electricity because it contains high voltage.
- When removing a PCB or related component, after unfastening or changing a wire, be sure to put the wire back in its original position.
- When you exchange IC and Transistor with a heat sink, apply silicon grease on the contact section of the heat sink. Before applying new silicon grease, remove all the old silicon grease. (Old grease may cause damages to the IC and Transistor.)

Prepare the following measurement tools for electrical adjustments.

1. Synchro Scope
2. Digital Voltmeter

On-Screen Display Adjustment

1. In the condition of NO indication on the screen. Press the VOL. DOWN button on the set and the Channel button (9) on the remote control for more than 2 seconds to appear the adjustment mode on the screen as shown in Fig. 1-1.

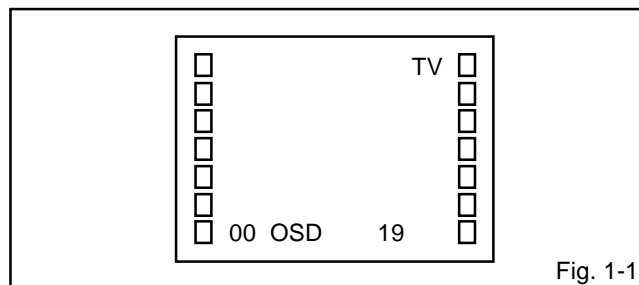

Fig. 1-1

2. Use the Channel UP/DOWN button or Channel button (0-9) on the remote control to select the options shown in Fig. 1-2.
3. Press the MENU button on the remote control to end the adjustments.

| NO. | FUNCTION | NO. | FUNCTION |
|-----|-------------|-----|---------------|
| 00 | OSD H | 16 | CONTRAST CENT |
| 01 | CUT OFF | 17 | CONTRAST MAX |
| 04 | H.VCO | 18 | CONTRAST MIN |
| 05 | H.PHASE | 19 | COLOR CENT |
| 06 | V.SIZE | 20 | COLOR MAX |
| 07 | V.SHIFT | 21 | COLOR MIN |
| 08 | R.DRIVE | 22 | TINT |
| 09 | B.DRIVE | 23 | SHARPNESS |
| 10 | R.BIAS | 24 | FM LEVEL |
| 11 | G.BIAS | 25 | LEVEL |
| 12 | B.BIAS | 26 | SEPARATION 1 |
| 13 | BRIGHT CENT | 27 | SEPARATION 2 |
| 14 | BRIGHT MAX | 28 | TEST MONO |
| 15 | BRIGHT MIN | 29 | TEST STEREO |

Fig. 1-2

2. BASIC ADJUSTMENTS

2-1: CUT OFF

1. Adjust the unit to the following settings.
R.DRIVE=10, B.DRIVE=10, R.BIAS=64, G.BIAS=64, B.BIAS=64, BRI.CENT=120, CONT.MAX=40.
2. Place the set in Aging Test for more than 15 minutes.
3. Activate the adjustment mode display of Fig. 1-1 and press the channel button (01) on the remote control to select "CUT OFF".
4. Adjust the **Screen Volume** until a dim raster is obtained.

2-2: FOCUS

1. Receive the monoscope pattern.
2. Turn the Focus Volume fully counterclockwise once.
3. Adjust the **Focus Volume** until picture is distinct.

2-3: WHITE BALANCE

NOTE: Adjust after performing CUT OFF adjustment.

1. Place the set in Aging Test for more than 10 minutes.
2. Receive the white 100% signal from the Pattern Generator.
3. Using the adjustment control, set the brightness and contrast to normal position.
4. Activate the adjustment mode display of Fig. 1-1 and press the channel button (10) on the remote control to select "R.BIAS".
5. Using the VOL. UP/DOWN button on the remote control, adjust the R.BIAS.
6. Press the CH. UP/DOWN button on the remote control to select the "R.DRIVE", "B.DRIVE", "G.BIAS" or "B.BIAS".
7. Using the VOL. UP/DOWN button on the remote control, adjust the R.DRIVE, B.DRIVE, G.BIAS or B.BIAS.
8. Perform the above adjustments 6 and 7 until the white color is achieved.

2-4: SUB TINT/SUB COLOR

1. Receive the color bar pattern. (RF Input)
2. Connect the oscilloscope to TP023.
3. Activate the adjustment mode display of Fig. 1-1 and press the channel button (22) on the remote control to select "TINT".
4. Press the VOL. UP/DOWN button on the remote control until the section "A" becomes as straight line. (Refer to Fig. 2-1)
5. Connect the oscilloscope to TP022.
6. Activate the adjustment mode display of Fig. 1-1 and press the channel button (19) on the remote control to select "COL.CENT".
7. Press the VOL. UP/DOWN button on the remote control until the red color level is adjusted to $110 \pm 10\%$ of the white level. (Refer to Fig. 2-2)
8. Receive the color bar pattern. (Audio Video Input)
9. Press the TV/VIDEO button on the remote control to set to the AV mode. Then perform the above adjustments 2-7.

ELECTRICAL ADJUSTMENTS

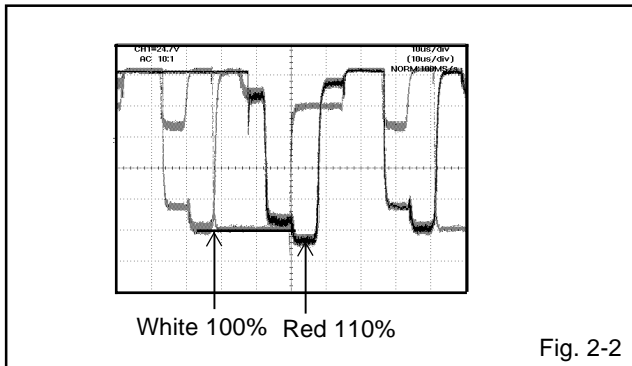
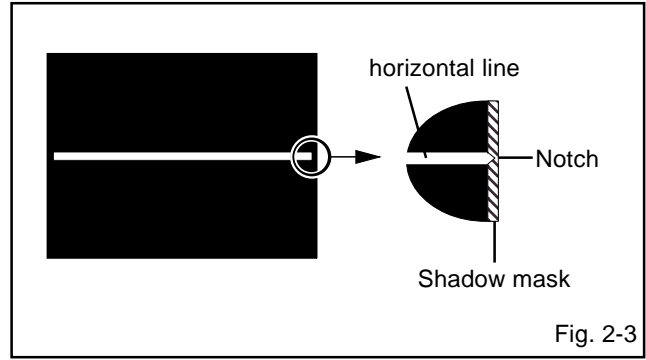
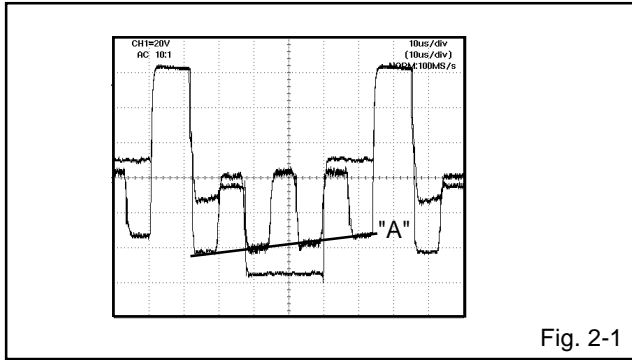

2-8: OSD HORIZONTAL

1. Activate the adjustment mode display of **Fig. 1-1**.
2. Press the VOL. UP/DOWN button on the remote control until the difference of A and B becomes minimum. (Refer to **Fig. 2-4**)

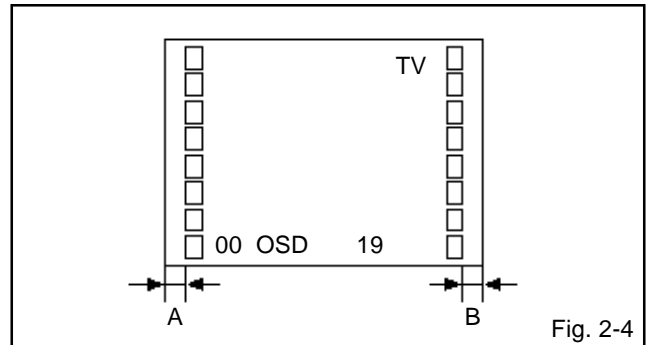

2-5: HORIZONTAL PHASE

1. Receive the monoscope pattern.
2. Using the adjustment control, set the brightness and contrast to normal position.
3. Activate the adjustment mode display of **Fig. 1-1** and press the channel button (05) on the remote control to select "H.PHAS".
4. Press the VOL. UP/DOWN button on the remote control until the SHIFT quantity of the OVER SCAN on right and left becomes minimum.

2-6: VERTICAL SIZE

1. Receive the monoscope Pattern.
2. Using the adjustment control, set the brightness and contrast to normal position.
3. Activate the adjustment mode display of **Fig. 1-1** and press the channel button (06) on the remote control to select "V.SIZE".
4. Press the VOL. UP/DOWN button on the remote control until the SHIFT quantity of the OVER SCAN on upside and downside becomes $10 \pm 2\%$.

2-7: VERTICAL SHIFT

1. Receive the monoscope Pattern.
2. Using the adjustment control, set the brightness and contrast to normal position.
3. Activate the adjustment mode display of **Fig. 1-1** and press the channel button (07) on the remote control to select "V.SFT".
4. Press the VOL. UP/DOWN button on the remote control until the horizontal line becomes fit to the notch of the shadow mask. (Refer to **Fig. 2-3**)

2-9: BRIGHT MANUAL

1. Receive the monoscope pattern.(RF Input)
2. Using the adjustment control, set the brightness and contrast to normal position.
3. Activate the adjustment mode display of **Fig. 1-1** and press the channel button (13) on the remote control to select "BRI.CENT".
4. Press the VOL.UP/DOWN button on the remote control until the white 10% is starting to be visible.
5. Press the TV/VIDEO button on the remote to set to the AV mode. Then perform the above adjustment 2-4.

2-10: SUB CONTRAST

1. Receive an 70dB the color bar pattern.
2. Activate the adjustment mode display of **Fig. 1-1** press the channel button (17) on the remote control to select "CONT.MAX".
3. Press the VOL. UP/DOWN button on the remote control until the contrast step No. becomes "43".
4. Press the TV/VIDEO button on the remote control to set to the AV mode.
5. Activate the adjustment mode display of **Fig. 1-1** pass the channel button (17) on the remote control to select "CONT.MAX".
6. Press the VOL.UP/DOWN button on the remote control until the contrast step No. becomes "52".
7. Receive a broadcast and check if the picture is normal.

ELECTRICAL ADJUSTMENTS

2-11: Confirmation of Fixed Value (step No.)

Please check if the fixed values of the each adjustment items are set correctly referring below. (RF/AV)

| NO. | FUNCTION | STEP NO. | NO. | FUNCTION | STEP NO. |
|------------|-----------------|-----------------|------------|-----------------|-----------------|
| 04 | H VCO | 04 | 21 | COLOR MIN | 00 |
| 14 | BRIGHT MAX | 140 | 23 | SHARPNESS | 53 |
| 15 | BRIGHT MIN | 60 | 24 | FM LEVEL | 00 |
| 16 | CONT CENT | 30 | 25 | LEVEL | 00 |
| 18 | CONT MIN | 15 | 26 | SEPARATION 1 | 00 |
| 20 | COLOR MAX | 74 | 27 | SEPARATION 2 | 00 |

ELECTRICAL ADJUSTMENTS

3. PURITY AND CONVERGENCE ADJUSTMENTS

NOTE

1. Turn the unit on and let it warm up for at least 30 minutes before performing the following adjustments.
2. Place the CRT surface facing east or west to reduce the terrestrial magnetism.
3. Turn ON the unit and demagnetize with a Degauss Coil.

3-1: STATIC CONVERGENCE (ROUGH ADJUSTMENT)

1. Tighten the screw for the magnet. Refer to the adjusted CRT for the position. **(Refer to Fig. 3-1)**
If the deflection yoke and magnet are in one body, untighten the screw for the body.
2. Receive the green raster pattern from the color bar generator.
3. Slide the deflection yoke until it touches the funnel side of the CRT.
4. Adjust center of screen to green, with red and blue on the sides, using the pair of purity magnets.
5. Switch the color bar generator from the green raster pattern to the crosshatch pattern.
6. Combine red and blue of the 3 color crosshatch pattern on the center of the screen by adjusting the pair of 4 pole magnets.
7. Combine red/blue (magenta) and green by adjusting the pair of 6 pole magnets.
8. Adjust the crosshatch pattern to change to white by repeating steps 6 and 7.

3-2: PURITY

NOTE

Adjust after performing adjustments in section 3-1.

1. Receive the green raster pattern from color bar generator.
2. Adjust the pair of purity magnets to center the color on the screen.
Adjust the pair of purity magnets so the color at the ends are equally wide.
3. Move the deflection yoke backward (to neck side) slowly, and stop it at the position when the whole screen is green.
4. Confirm red and blue colors.
5. Adjust the slant of the deflection yoke while watching the screen, then tighten the fixing screw.

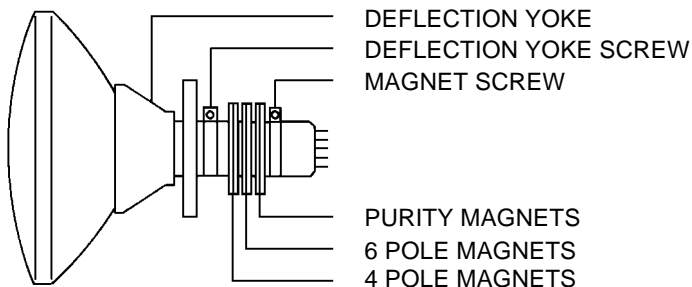

Fig. 3-1

3-3: STATIC CONVERGENCE

NOTE

Adjust after performing adjustments in section 3-2.

1. Receive the crosshatch pattern from the color bar generator.
2. Combine red and blue of the 3 color crosshatch pattern on the center of the screen by adjusting the pair of 4 pole magnets.
3. Combine red/blue (magenta) and green by adjusting the pair of 6 pole magnets.

3-4: DYNAMIC CONVERGENCE

NOTE

Adjust after performing adjustments in section 3-3.

1. Adjust the differences around the screen by moving the deflection yoke upward/downward and right/left. **(Refer to Fig. 3-2-a)**
2. Insert three wedges between the deflection yoke and CRT funnel to fix the deflection yoke. **(Refer to Fig. 3-2-b)**

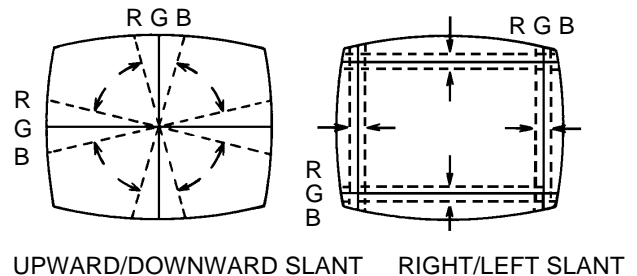

Fig. 3-2-a

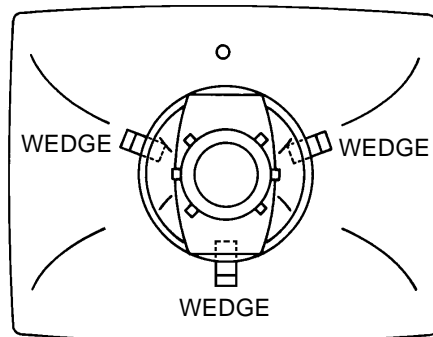
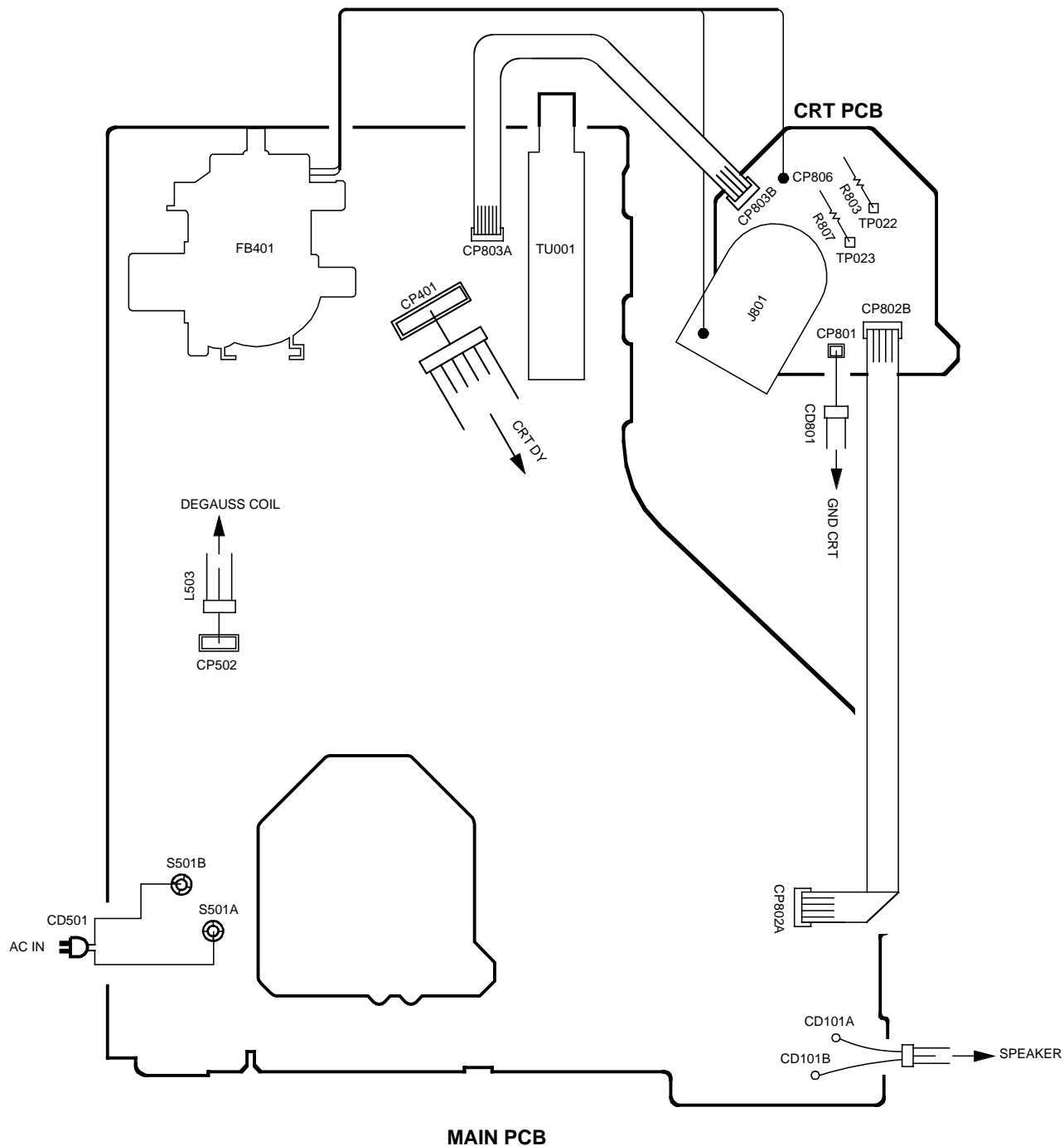

Fig. 3-2-b

ELECTRICAL ADJUSTMENTS

4. ELECTRICAL ADJUSTMENT PARTS LOCATION GUIDE (WIRING CONNECTION)



MECHANICAL EXPLODED VIEW

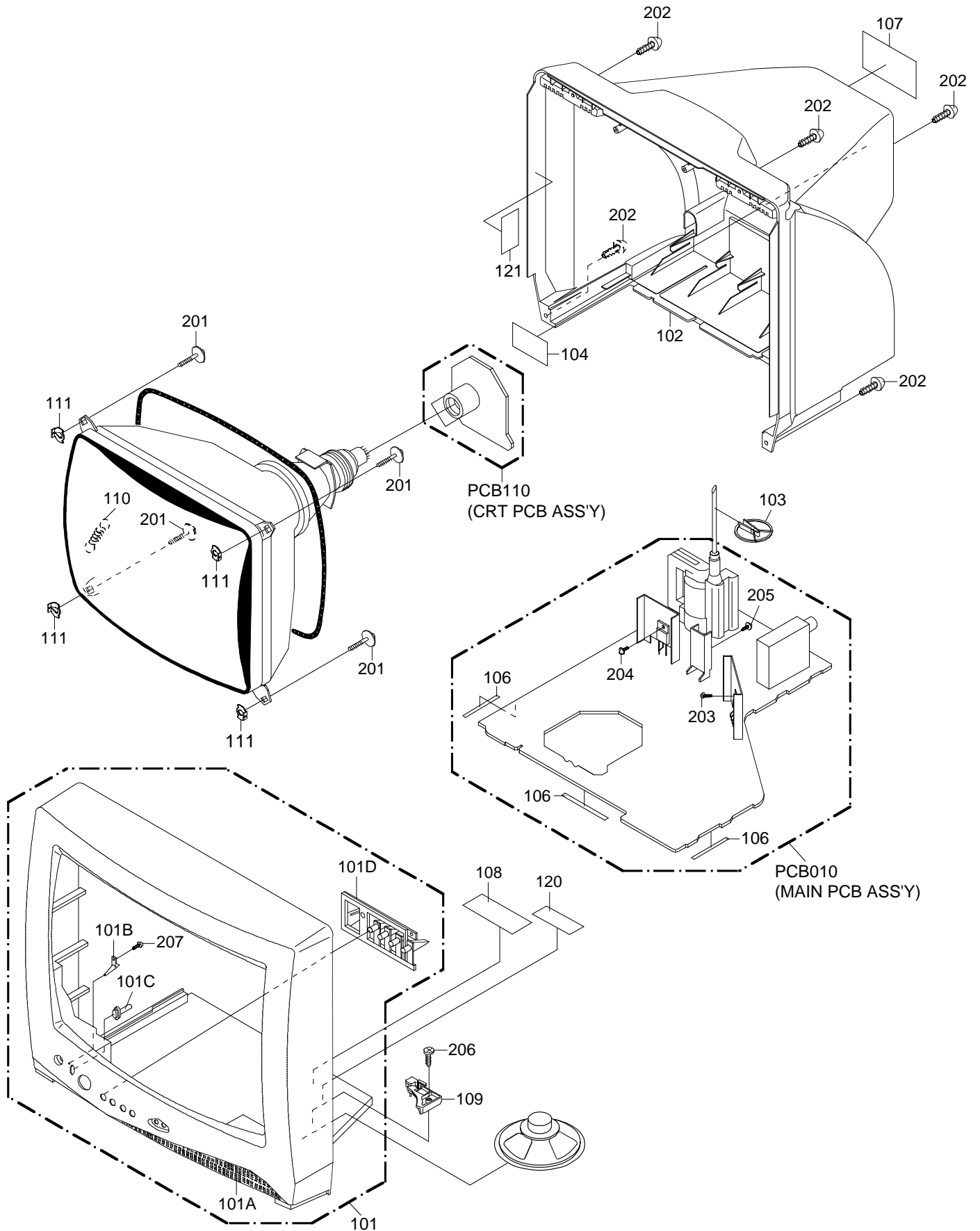

MECHANICAL EXPLODED VIEW (PACKING DIAGRAM)

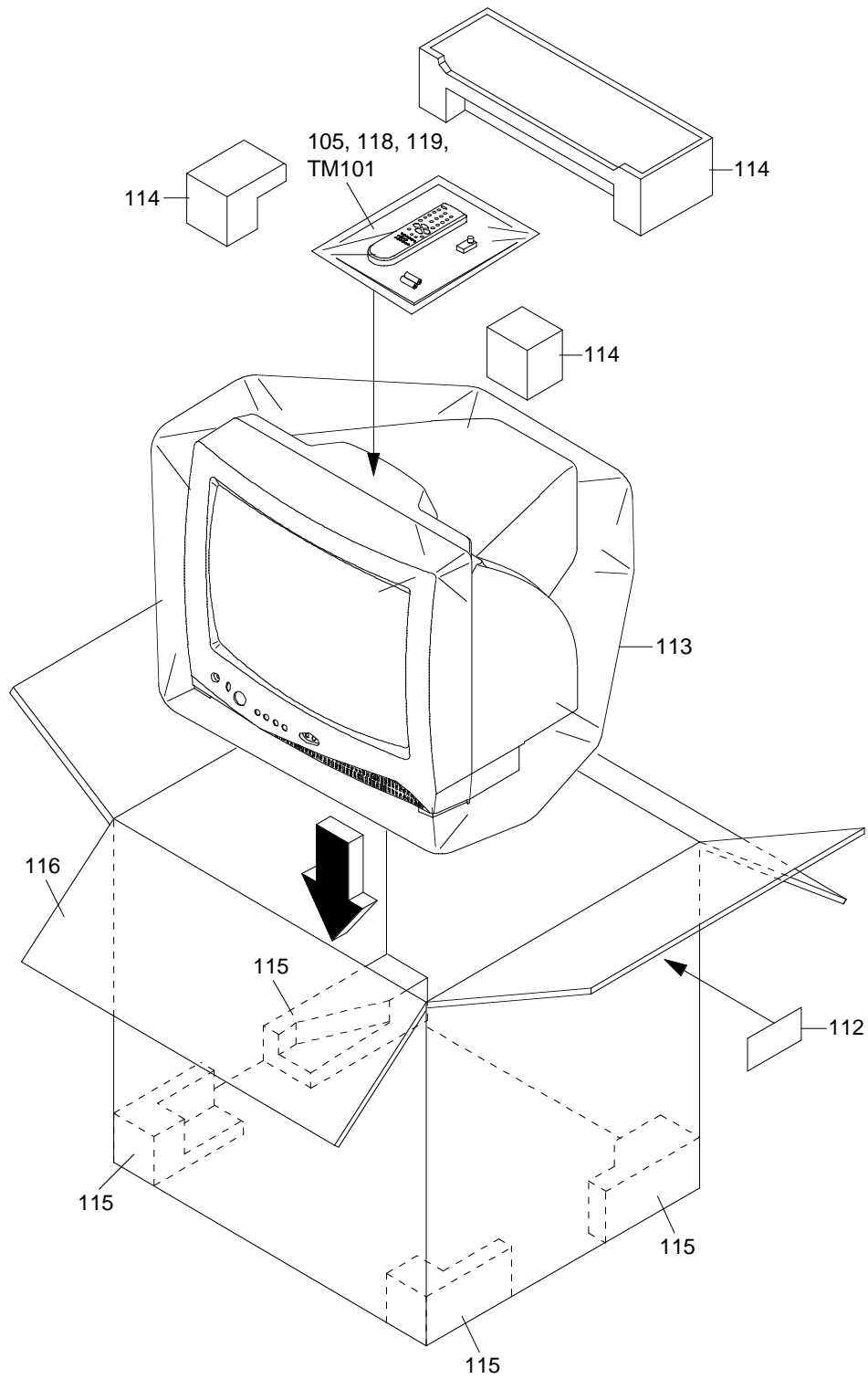

MECHANICAL REPLACEMENT PARTS LIST

| Location No. | TSB P/N | Reference No. | Description | |
|--------------|----------|---------------|----------------------------------|------|
| 101 | AE006001 | 7A701A312A | FRONT CABI ASS'Y | |
| 101A | AE005701 | 701WPJC918 | CABINET,FRONT | |
| 101B | AE005702 | 713WPAA203 | GLASS,LED | |
| 101C | AE005703 | 713WPAA202 | GUIDE,REMOCON | |
| 101D | AE005704 | 735WPBB315 | BUTTON,FRAME | |
| 102 | AE006002 | A3M131X740 | CABINET,BACK ASS'Y | |
| 103 | BZ710260 | 899HV3T000 | HOLDER,ANODE WIRE | |
| 104 | AE007109 | 726000A101 | SHEET,CRT SERVICEMAN | |
| 105 | AE005707 | J3M13121A | INSTRUCTION BOOK(E/S) | |
| 106 | AE000535 | 800WQ0A024 | FELT SHEET | |
| 107 | AE005708 | 722549A412 | SHEET,RATING | |
| 108 | AE005650 | 723000C727 | SHEET,CAUTION | |
| 109 | AE005709 | 735WPAA837 | SPEAKER HOLDER | |
| 110 | BZ710660 | 741WUA0021 | SPRING,EARTH | |
| 111 | AE005971 | 769WSAA012 | WASHER CRT T=0.5 | |
| 112 | AE007110 | 723000C835 | SHEET,BARCODE | |
| 113 | AE005712 | 791WHAA122 | FILM BAG | |
| 114 | AD300809 | 792WHAA052 | PACKAGE,TOP | |
| 115 | AD300810 | 792WHAA053 | PACKAGE,BOTTOM | |
| 116 | AE005713 | 793WCDC593 | GIFT BOX | |
| 117 | AE005714 | A3M131V975 | INSTRUCTION BOOK KIT | |
| 118 | AE005715 | JB5KD200 | POLYBAG,INSTRUCTION(RED CAUTION) | |
| 119 | AE004983 | J2D60117A | REGISTRATION CARD | |
| 201 | AE005716 | 8121J50B5U | SCREW,TAP TITE(P) GW20 | 5x28 |
| 202 | AE004847 | 8117540A6U | SCREW,TAP TITE(B0) TRUSS | 4x16 |
| 203 | AE003531 | 810763080U | SCREW,TAP TITE(S) BRAZIER | 3x8 |
| 204 | AE005717 | 8109I3060U | SCREW,TAP TITE(B) WH7 | 3x6 |
| 205 | AE005659 | 8109I3080U | SCREW,TAP TITE(B) WH7 | 3x8 |
| 206 | AE003528 | 8110630A0U | SCREW,TAP TITE(P) BRAZIER | 3x10 |
| 207 | AE003529 | 811063080U | SCREW,TAP TITE(P) BRAZIER | 3x8 |

MECHANICAL REPLACEMENT PARTS LIST

| Location No. | TSB P/N | Reference No. | Description | |
|--------------|----------|---------------|----------------------------------|------|
| 101 | AE006001 | 7A701A312A | FRONT CABI ASS'Y | |
| 101A | AE005701 | 701WPJC918 | CABINET,FRONT | |
| 101B | AE005702 | 713WPAA203 | GLASS,LED | |
| 101C | AE005703 | 713WPAA202 | GUIDE,REMOCON | |
| 101D | AE005704 | 735WPBB315 | BUTTON,FRAME | |
| 102 | AE007111 | A3M132X740 | CABINET,BACK ASS'Y | |
| 103 | BZ710260 | 899HV3T000 | HOLDER,ANODE WIRE | |
| 104 | AE007109 | 726000A101 | SHEET,CRT SERVICEMAN | |
| 105 | AE007112 | J3M13221A | INSTRUCTION BOOK | |
| 106 | AE000535 | 800WQ0A024 | FELT SHEET | |
| 107 | AE007113 | 722549A440 | SHEET,RATING | |
| 108 | AE006290 | 723000C728 | SHEET,CAUTION | |
| 109 | AE005709 | 735WPAA837 | SPEAKER HOLDER | |
| 110 | BZ710660 | 741WUA0021 | SPRING,EARTH | |
| 111 | AE005971 | 769WSAA012 | WASHER CRT T=0.5 | |
| 112 | AE007114 | 723000C853 | SHEET,BARCODE | |
| 113 | AE005712 | 791WHAA122 | FILM BAG | |
| 114 | AD300809 | 792WHAA052 | PACKAGE, TOP | |
| 115 | AD300810 | 792WHAA053 | PACKAGE,BOTTOM | |
| 116 | AE007115 | 793WCDC661 | GIFT BOX | |
| 117 | AE007116 | A3M132X975 | INSTRUCTION BOOK KIT | |
| 118 | AE007117 | JB5KD100 | POLYBAG,INSTRUCTION(RED CAUTION) | |
| 120 | AE000091 | 722000A023 | SHEET,HWC | |
| 121 | AE006166 | 722000A267 | SHEET,CSA WARNING | |
| 201 | AE005716 | 8121J50B5U | SCREW,TAP TITE(P) GW20 | 5x28 |
| 202 | AE004847 | 8117540A6U | SCREW,TAP TITE(B0) TRUSS | 4x16 |
| 203 | AE003531 | 810763080U | SCREW,TAP TITE(S) BRAZIER | 3x8 |
| 204 | AE005717 | 8109I3060U | SCREW,TAP TITE(B) WH7 | 3x6 |
| 205 | AE005659 | 8109I3080U | SCREW,TAP TITE(B) WH7 | 3x8 |
| 206 | AE003528 | 8110630A0U | SCREW,TAP TITE(P) BRAZIER | 3x10 |
| 207 | AE003529 | 811063080U | SCREW,TAP TITE(P) BRAZIER | 3x8 |

ELECTRICAL REPLACEMENT PARTS LIST

| Location No. | TSB P/N | Reference No. | Description |
|-------------------|----------|---------------|---------------------------------|
| RESISTORS | | | |
| △R401 | AE005733 | R4K1T4273F | R,METAL 2.27K OHM 1/4W |
| △R404 | AE004065 | R615U2151J | R,FUSE 150 OHM 1/2W |
| △R408 | AE005732 | R4K1T4103F | R,METAL 2.10K OHM 1/4W |
| △R409 | AE005733 | R4K1T4273F | R,METAL 2.27K OHM 1/4W |
| △R429 | AE005699 | R638814R7J | R,FUSE 4.7 OHM 1W |
| △R447 | AE005729 | R3K58A151J | R,METAL OXIDE 150 OHM 2W |
| △R500 | BZ210080 | R0G3K2275K | RC 2.7M OHM 1/2W |
| △R501 | AE000366 | R5X2CD5R6J | R,CEMENT 5.6 OHM 5W |
| △R508 | AE005727 | R3K581221J | R,METAL OXIDE 220 OHM 1W |
| R509 | BZ210135 | R002T4221J | RC 220 OHM 1/4W |
| R510 | AE003327 | R00202335J | RC 3.3M OHM 1/2W |
| △R514 | AE005735 | R63881R22J | R,FUSE 0.22 OHM 1W |
| R515 | BZ210081 | R002T2124J | RC 120K OHM 1/2W |
| △R517 | AE005726 | R3K581010J | R,METAL OXIDE 1 OHM 1W |
| △R518 | AE005734 | R4K1T4562F | R,METAL 5.6K OHM 1/4W |
| △R519 | BZ210124 | R002T4122J | RC 1.2K OHM 1/4W |
| △R525 | AE005730 | R3K58A1R5J | R,METAL OXIDE 1.5 OHM 2W |
| △R538 | BZ210206 | R002T2155J | RC 1.5M OHM 1/2W |
| △R542 | AE005728 | R3K581R68J | R,METAL OXIDE 0.68 OHM 1W |
| △R629 | AE005731 | R3K58B220J | R,METAL OXIDE 22 OHM 3W |
| △R803 | AE005689 | R3K581153J | R,METAL OXIDE 15K OHM 1W |
| △R805 | AE005689 | R3K581153J | R,METAL OXIDE 15K OHM 1W |
| △R807 | AE005689 | R3K581153J | R,METAL OXIDE 15K OHM 1W |
| CAPACITORS | | | |
| △C403 | BZ110149 | E02LT4471M | CE 470 UF 35V |
| △C414 | AD301434 | E02LU4101M | CE 100 UF 35V |
| △C418 | BZ110041 | E02LT3471M | CE 470 UF 25V |
| C420 | BZ110203 | C0PLRR7W2K | CC 820 PF 2KV RR |
| △C434 | BZ110195 | E02LU8220M | CE 22 UF 100V |
| C437 | BZ210173 | P4J7F3474J | CMPP 0.47 UF 250V PMS |
| △C443 | AE001322 | P4N8FJ842H | CMPP 0.0084UF 1.25KV |
| C446 | BZ110205 | E02LU5220M | CE 22 UF 50V |
| △C448 | BZ110204 | E0ELFD220M | CE 22 UF 250V |
| C503 | BZ110061 | C0JTB0513K | CC 0.001 UF 500V B |
| △C505 | BZ110025 | P2122B224M | CMP 0.22 UF 275V ECQUL |
| △C506 | AD301026 | CD39EOM13M | CC 0.001 UF 250V |
| △C508 | AE002878 | CD39E0MQ3M | CC 0.0047UF 250V |
| C514 | BZ110203 | C0PLRR7W2K | CC 820 PF 2KV RR |
| △C515 | BZ110135 | E02L02222M | CE 2200 UF 16V |
| C517 | BZ110203 | C0PLRR7W2K | CC 820 PF 2KV RR |
| △C519 | BZ110207 | E02LT2102M | CE 1000 UF 16V |
| △C521 | BZ110092 | E5EZFB101M | CE 100 UF 160V |
| △C526 | BZ110089 | E02LFC221M | CE 220 UF 200V |
| C819 | BZ110247 | C0JBB0713K | CC 0.001 UF 2KV B |
| DIODES | | | |
| D001 | BZ410037 | D97U03301B | DIODE,ZENER MTZJ33B T-77 |
| D106 | BZ410054 | 0021721150 | LED SLR-342VCT32 |
| D403 | BZ410043 | D2WT011E10 | DIODE,SILICON 11E1-EIC |
| D404 | BZ410066 | D97U06R21B | DIODE,ZENER MTZJ6.2B T-77 |
| △D405 | BZ410063 | D2WTAU02A0 | DIODE,SILICON AU02A-EIC |
| △D406 | BZ410043 | D2WT011E10 | DIODE,SILICON 11E1-EIC |
| D408 | BZ410043 | D2WT011E10 | DIODE,SILICON 11E1-EIC |
| D409 | BZ410043 | D2WT011E10 | DIODE,SILICON 11E1-EIC |
| △D410 | BZ410063 | D2WTAU02A0 | DIODE,SILICON AU02A-EIC |
| △D411 | BZ410063 | D2WTAU02A0 | DIODE,SILICON AU02A-EIC |
| △D412 | BZ410020 | D97U05R11B | DIODE,ZENER MTZJ5.1B T-77 |
| △D501 | BZ410085 | D2WXN40050 | DIODE,SILICON 1N4005-EIC |
| △D502 | BZ410085 | D2WXN40050 | DIODE,SILICON 1N4005-EIC |
| △D503 | BZ410085 | D2WXN40050 | DIODE,SILICON 1N4005-EIC |
| △D504 | BZ410085 | D2WXN40050 | DIODE,SILICON 1N4005-EIC |
| △D505 | BZ410010 | D28T21DQN9 | DIODE,SCHOTTKY 21DQ09N-TA2B1 |
| D506 | AD300671 | D97U01801B | DIODE,ZENER MTZJ18B T-77 |
| D508 | BZ410006 | D1VT001330 | DIODE,SILICON 1SS133T-77 |
| △D509 | AD300671 | D97U01801B | DIODE,ZENER MTZJ18B T-77 |
| △D510 | BZ410080 | D2WXRU2AM0 | DIODE,SILICON RU2AM-EIC |
| D511 | BZ410006 | D1VT001330 | DIODE,SILICON 1SS133T-77 |
| △D512 | BZ410006 | D1VT001330 | DIODE,SILICON 1SS133T-77 |
| △D513 | BZ410010 | D28T21DQN9 | DIODE,SCHOTTKY 21DQ09N-TA2B1 |
| D514 | BZ410006 | D1VT001330 | DIODE,SILICON 1SS133T-77 |
| D515 | AD300731 | D2WXN49370 | DIODE,SILICON 1N4937 |
| △D516 | AD300731 | D2WXN49370 | DIODE,SILICON 1N4937 |

ELECTRICAL REPLACEMENT PARTS LIST

| Location No. | TSB P/N | Reference No. | Description |
|---------------------------------|----------|---------------|----------------------------------------|
| DIODES | | | |
| D521 | BZ410022 | D97U06R81B | DIODE,ZENER MTZJ6.8B T-77 |
| D522 | BZ410006 | D1VT001330 | DIODE,SILICON 1SS133T-77 |
| D528 | BZ410021 | D97U05R61B | DIODE,ZENER MTZJ5.6B T-77 |
| D602 | BZ410023 | D97U09R11B | DIODE,ZENER MTZJ9.1B T-77 |
| D603 | BZ410006 | D1VT001330 | DIODE,SILICON 1SS133T-77 |
| D604 | BZ410058 | D97U08R21B | DIODE,ZENER MTZJ8.2B T-77 |
| D606 | BZ410043 | D2WT011E10 | DIODE,SILICON 11E1-EIC |
| ICS | | | |
| IC101 | AE005644 | I56F07091C | IC OEC7091C |
| IC199 | AE005724 | A3M131V015 | INIT DATA BR24L02F-WE2 |
| △IC401 | AE002783 | I03TD804N0 | IC LA78040N-E |
| △IC501 | BZ410088 | 0002E00610 | PHOTO COUPLER LTV-817M-VB |
| IC1001 | BZ611001 | I01DP75110 | IC AN7511 |
| TRANSISTORS | | | |
| Q105 | BZ510086 | TPATB03003 | COMPOUND TRANSISTOR KRA102MAT |
| △Q401 | AE000656 | TC1G058850 | TRANSISTOR,SILICON 2SC5885 |
| △Q402 | BZ510089 | TC5T01627Y | TRANSISTOR,SILICON 2SC1627_Y(TPE2) |
| △Q501 | AE002251 | T25F035630 | FET 2SK3563(ORION_Q) |
| △Q502 | BZ510069 | TCATC31980 | TRANSISTOR,SILICON KTC3198-AT(Y,GR) |
| △Q503 | BZ510004 | TA3T016240 | TRANSISTOR,SILICON 2SA1624-AA |
| Q505 | BZ510073 | TAATA12660 | TRANSISTOR,SILICON KTA1266-AT(Y,GR) |
| Q507 | BZ510069 | TCATC31980 | TRANSISTOR,SILICON KTC3198-AT(Y,GR) |
| Q601 | BZ510070 | TCAT032034 | TRANSISTOR,SILICON KTC3203_Y-AT |
| Q602 | BZ510070 | TCAT032034 | TRANSISTOR,SILICON KTC3203_Y-AT |
| Q603 | BZ510070 | TCAT032034 | TRANSISTOR,SILICON KTC3203_Y-AT |
| Q606 | BZ510070 | TCAT032034 | TRANSISTOR,SILICON KTC3203_Y-AT |
| Q607 | BZ510069 | TCATC31980 | TRANSISTOR,SILICON KTC3198-AT(Y,GR) |
| △Q801 | AD300794 | TCKT1473A0 | TRANSISTOR,SILICON 2SC1473A-TA-(RQ) |
| △Q802 | AD300794 | TCKT1473A0 | TRANSISTOR,SILICON 2SC1473A-TA-(RQ) |
| △Q803 | AD300794 | TCKT1473A0 | TRANSISTOR,SILICON 2SC1473A-TA-(RQ) |
| COILS & TRANSFORMERS | | | |
| L001 | AE000290 | 02167F3R3J | COIL 3.3 UH |
| L401 | AD301644 | 021L75472J | COIL 4.7 MH |
| △L501 | AE005719 | 0293000130 | COIL,LINE FILTER ELF15N010AP |
| △L503 | AE005718 | 028B140033 | COIL,DEGAUSS DYD1-3020-80 |
| L801 | BZ310113 | 021673221K | COIL 220 UH |
| T401 | BZ310157 | 045009003J | TRANS,HORIZONTAL DRIVE ETH09K14BZ |
| △T502 | AD302162 | 0481291084 | TRANSFORMER,SWITCHING 81291084 |
| JACKS | | | |
| J702 | AE005633 | 060Q401112 | RCA JACK AV1-09AD-3 |
| J703 | AE005632 | 060Q401111 | RCA JACK AV1-09AD-4 |
| △J801 | BZ614434 | 066F120018 | SOCKET,CATHODE RAY TUBE ISMS01S |
| △J1001 | AD302163 | 060J121014 | JACK,RCA,3.5 MSJ-035-12A_PC |
| SWITCHES | | | |
| SW101 | BZ612010 | 0504101T34 | SWITCH,TACT EVQ21505R |
| SW102 | BZ612010 | 0504101T34 | SWITCH,TACT EVQ21505R |
| SW103 | BZ612010 | 0504101T34 | SWITCH,TACT EVQ21505R |
| SW104 | BZ612010 | 0504101T34 | SWITCH,TACT EVQ21505R |
| SW105 | BZ612010 | 0504101T34 | SWITCH,TACT EVQ21505R |
| P.C.BOARD ASSEMBLIES | | | |
| PCB010 | AE005723 | A3M131V010 | PCB ASS'Y CMD009A |
| PCB110 | AE005725 | A3M131V110 | PCB ASS'Y CCD004A |
| MISCELLANEOUS | | | |
| B501 | BZ310121 | 024HT03553 | CORE,BEADS W5RH3.5X5X1.0 |
| B504 | BZ310121 | 024HT03553 | CORE,BEADS W5RH3.5X5X1.0 |
| BT001 | AE005640 | 141R004016 | BATTERY,MANGAN GR03X-SP2 |
| BT002 | AE005640 | 141R004016 | BATTERY,MANGAN GR03X-SP2 |
| △CD501 | AE005639 | 1209414909 | CORD,AC BUSH 9414909 |
| △CP401 | BZ614303 | 069S450089 | CONNECTOR PCB SIDE A1561WV2-A5P |
| △CP502 | BZ614283 | 069S420110 | CONNECTOR PCB SIDE A1561WV2-2P |
| CP503 | BZ614016 | 069W01001A | CONNECTOR PCB SIDE 003P-2100 |
| CP601 | AE005634 | 069S260639 | CONNECTOR PCB SIDE A2001WR2-6P |
| CP801 | AE007181 | 069W010340 | CONNECTOR PCB SIDE 131001101K1 |
| CD101A | AE005720 | 06C3012004 | CORD,CONNECTOR C3012004 |
| CD101B | AE005721 | 06C3012005 | CORD,CONNECTOR C3012005 |
| CP802A | BZ614276 | 067U005049 | WIRE HOLDER B2013H02-5P |
| CP802B | BZ614276 | 067U005049 | WIRE HOLDER B2013H02-5P |
| CP803A | BZ614334 | 067U004029 | WIRE HOLDER B2013H02-4P |
| CP803B | BZ614334 | 067U004029 | WIRE HOLDER B2013H02-4P |
| EL001 | BZ614043 | 124116281A | EYE LET XRY16X28BD |
| EL002 | BZ614044 | 124120301A | EYE LET XRY20X30BD |

ELECTRICAL REPLACEMENT PARTS LIST

| Location No. | TSB P/N | Reference No. | Description |
|----------------------|-----------|-------------------------------|-----------------------------------------|
| MISCELLANEOUS | | | |
| △ F501 | AD302166 | 081PC04005 | FUSE 51MS040L |
| △ FB401 | AE003330 | 043214050F | TRANSFORMER,FLYBACK FN114B002_M |
| FH501 | AE002634 | 06710T0009 | HOLDER,FUSE EYF-52BCY |
| FH502 | AE002634 | 06710T0009 | HOLDER,FUSE EYF-52BCY |
| OS101 | AD301048 | 0773071001 | REMOTE RECEIVER RPM7138-WH5 |
| S101 | AD302168 | WBL6026038 | FLAT CABLE AWM2468 AWG26 4C BLACK 260MM |
| S102 | BZ614371 | WCL6834038 | FLAT CABLE AWM2468 AWG26 5C GRAY 340MM |
| △ SP1001 | AE005722 | 070Y132027 | SPEAKER S08F21A |
| △ TH501 | AD302000 | D8EE0B1400 | DEGAUSS ELEMENT B59203-S1060-B14 |
| TM101 | AE003331 | 076N0EH050 | TRANSMITTER RC-EH050(CT-859) |
| △ TU001 | AE006069 | 0163300018 | RF UNIT 115-V-KA35ARB |
| △ V801 | BZ614442 | 098Y1404C8 | CRT W/DY A34JXV70X73N45 |
| X601 | BZ613004 | 100CT3R505 | CRYSTAL HC-49/U |
| | | | |
| RESISTOR | | | |
| | RC..... | CARBON RESISTOR | |
| | | | |
| CAPACITORS | | | |
| | CC..... | CERAMIC CAPACITOR | |
| | CE..... | ALUMI ELECTROLYTIC CAPACITOR | |
| | CP..... | POLYESTER CAPACITOR | |
| | CPP..... | POLYPROPYLENE CAPACITOR | |
| | CPL..... | PLASTIC CAPACITOR | |
| | CMP..... | METAL POLYESTER CAPACITOR | |
| | CMPL..... | METAL PLASTIC CAPACITOR | |
| | CMPP..... | METAL POLYPROPYLENE CAPACITOR | |

ELECTRICAL REPLACEMENT PARTS LIST

| Location No. | TSB P/N | Reference No. | Description |
|-------------------|----------|---------------|---------------------------------|
| RESISTORS | | | |
| △R401 | AE005733 | R4K1T4273F | R,METAL 2.27K OHM 1/4W |
| △R404 | AE004065 | R615U2151J | R,FUSE 150 OHM 1/2W |
| △R408 | AE005732 | R4K1T4103F | R,METAL 2.10K OHM 1/4W |
| △R409 | AE005733 | R4K1T4273F | R,METAL 2.27K OHM 1/4W |
| △R429 | AE005699 | R638814R7J | R,FUSE 4.7 OHM 1W |
| △R447 | AE005729 | R3K58A151J | R,METAL OXIDE 150 OHM 2W |
| △R500 | BZ210080 | R0G3K2275K | RC 2.7M OHM 1/2W |
| △R501 | AE000366 | R5X2CD5R6J | R,CEMENT 5.6 OHM 5W |
| △R508 | AE005727 | R3K581221J | R,METAL OXIDE 220 OHM 1W |
| R509 | BZ210135 | R002T4221J | RC 220 OHM 1/4W |
| R510 | AE003327 | R00202335J | RC 3.3M OHM 1/2W |
| △R514 | AE005735 | R63881R22J | R,FUSE 0.22 OHM 1W |
| R515 | BZ210081 | R002T2124J | RC 120K OHM 1/2W |
| △R517 | AE005726 | R3K581010J | R,METAL OXIDE 1 OHM 1W |
| △R518 | AE005734 | R4K1T4562F | R,METAL 5.6K OHM 1/4W |
| △R519 | BZ210124 | R002T4122J | RC 1.2K OHM 1/4W |
| △R525 | AE005730 | R3K58A1R5J | R,METAL OXIDE 1.5 OHM 2W |
| △R538 | BZ210206 | R002T2155J | RC 1.5M OHM 1/2W |
| △R542 | AE005728 | R3K581R68J | R,METAL OXIDE 0.68 OHM 1W |
| △R629 | AE005731 | R3K58B220J | R,METAL OXIDE 22 OHM 3W |
| △R803 | AE005689 | R3K581153J | R,METAL OXIDE 15K OHM 1W |
| △R805 | AE005689 | R3K581153J | R,METAL OXIDE 15K OHM 1W |
| △R807 | AE005689 | R3K581153J | R,METAL OXIDE 15K OHM 1W |
| CAPACITORS | | | |
| △C403 | BZ110149 | E02LT4471M | CE 470 UF 35V |
| △C414 | AD301434 | E02LU4101M | CE 100 UF 35V |
| △C418 | BZ110041 | E02LT3471M | CE 470 UF 25V |
| C420 | BZ110203 | C0PLRR7W2K | CC 820 PF 2KV RR |
| △C434 | BZ110195 | E02LU8220M | CE 22 UF 100V |
| C437 | BZ210173 | P4J7F3474J | CMPP 0.47 UF 250V PMS |
| △C443 | AE001322 | P4N8FJ842H | CMPP 0.0084UF 1.25KV |
| C446 | BZ110205 | E02LU5220M | CE 22 UF 50V |
| △C448 | BZ110204 | E0ELFD220M | CE 22 UF 250V |
| C503 | BZ110061 | C0JTB0513K | CC 0.001 UF 500V B |
| △C505 | BZ110025 | P2122B224M | CMP 0.22 UF 275V ECQUL |
| △C506 | AD301026 | CD39EOM13M | CC 0.001 UF 250V |
| △C508 | AE002878 | CD39E0MQ3M | CC 0.0047UF 250V |
| C514 | BZ110203 | C0PLRR7W2K | CC 820 PF 2KV RR |
| △C515 | BZ110135 | E02L02222M | CE 2200 UF 16V |
| C517 | BZ110203 | C0PLRR7W2K | CC 820 PF 2KV RR |
| △C519 | BZ110207 | E02LT2102M | CE 1000 UF 16V |
| △C521 | BZ110092 | E5EZFB101M | CE 100 UF 160V |
| △C526 | BZ110089 | E02LFC221M | CE 220 UF 200V |
| C819 | BZ110247 | C0JBB0713K | CC 0.001 UF 2KV B |
| DIODES | | | |
| D001 | BZ410037 | D97U03301B | DIODE,ZENER MTZJ33B T-77 |
| D106 | BZ410054 | 0021721150 | LED SLR-342VCT32 |
| D403 | BZ410043 | D2WT011E10 | DIODE,SILICON 11E1-EIC |
| D404 | BZ410066 | D97U06R21B | DIODE,ZENER MTZJ6.2B T-77 |
| △D405 | BZ410063 | D2WTAU02A0 | DIODE,SILICON AU02A-EIC |
| △D406 | BZ410043 | D2WT011E10 | DIODE,SILICON 11E1-EIC |
| D408 | BZ410043 | D2WT011E10 | DIODE,SILICON 11E1-EIC |
| D409 | BZ410043 | D2WT011E10 | DIODE,SILICON 11E1-EIC |
| △D410 | BZ410063 | D2WTAU02A0 | DIODE,SILICON AU02A-EIC |
| △D411 | BZ410063 | D2WTAU02A0 | DIODE,SILICON AU02A-EIC |
| △D412 | BZ410020 | D97U05R11B | DIODE,ZENER MTZJ5.1B T-77 |
| △D501 | BZ410085 | D2WXN40050 | DIODE,SILICON 1N4005-EIC |
| △D502 | BZ410085 | D2WXN40050 | DIODE,SILICON 1N4005-EIC |
| △D503 | BZ410085 | D2WXN40050 | DIODE,SILICON 1N4005-EIC |
| △D504 | BZ410085 | D2WXN40050 | DIODE,SILICON 1N4005-EIC |
| △D505 | BZ410010 | D28T21DQN9 | DIODE,SCHOTTKY 21DQ09N-TA2B1 |
| D506 | AD300671 | D97U01801B | DIODE,ZENER MTZJ18B T-77 |
| D508 | BZ410006 | D1VT001330 | DIODE,SILICON 1SS133T-77 |
| △D509 | AD300671 | D97U01801B | DIODE,ZENER MTZJ18B T-77 |
| △D510 | BZ410080 | D2WXRU2AM0 | DIODE,SILICON RU2AM-EIC |
| D511 | BZ410006 | D1VT001330 | DIODE,SILICON 1SS133T-77 |
| △D512 | BZ410006 | D1VT001330 | DIODE,SILICON 1SS133T-77 |
| △D513 | BZ410010 | D28T21DQN9 | DIODE,SCHOTTKY 21DQ09N-TA2B1 |
| D514 | BZ410006 | D1VT001330 | DIODE,SILICON 1SS133T-77 |
| D515 | AD300731 | D2WXN49370 | DIODE,SILICON 1N4937 |
| △D516 | AD300731 | D2WXN49370 | DIODE,SILICON 1N4937 |

ELECTRICAL REPLACEMENT PARTS LIST

| Location No. | TSB P/N | Reference No. | Description |
|---------------------------------|----------|---------------|----------------------------------------|
| DIODES | | | |
| D521 | BZ410022 | D97U06R81B | DIODE,ZENER MTZJ6.8B T-77 |
| D522 | BZ410006 | D1VT001330 | DIODE,SILICON 1SS133T-77 |
| D528 | BZ410021 | D97U05R61B | DIODE,ZENER MTZJ5.6B T-77 |
| D602 | BZ410023 | D97U09R11B | DIODE,ZENER MTZJ9.1B T-77 |
| D603 | BZ410006 | D1VT001330 | DIODE,SILICON 1SS133T-77 |
| D604 | BZ410058 | D97U08R21B | DIODE,ZENER MTZJ8.2B T-77 |
| D606 | BZ410043 | D2WT011E10 | DIODE,SILICON 11E1-EIC |
| ICS | | | |
| IC101 | AE005644 | I56F07091C | IC OEC7091C |
| IC199 | AE007183 | A3M132X015 | INIT DATA BR24L02F-WE2 |
| △IC401 | AE002783 | I03TD804N0 | IC LA78040N-E |
| △IC501 | BZ410088 | 0002E00610 | PHOTO COUPLER LTV-817M-VB |
| IC1001 | BZ611001 | I01DP75110 | IC |
| TRANSISTORS | | | |
| Q105 | BZ510086 | TPATB03003 | COMPOUND TRANSISTOR KRA102MAT |
| △Q401 | AE000656 | TC1G058850 | TRANSISTOR,SILICON 2SC5885 |
| △Q402 | BZ510089 | TC5T01627Y | TRANSISTOR,SILICON 2SC1627_Y(TPE2) |
| △Q501 | AE002251 | T25F035630 | FET 2SK3563(ORION_Q) |
| △Q502 | BZ510069 | TCATC31980 | TRANSISTOR,SILICON KTC3198-AT(Y,GR) |
| △Q503 | BZ510004 | TA3T016240 | TRANSISTOR,SILICON 2SA1624-AA |
| Q505 | BZ510073 | TAATA12660 | TRANSISTOR,SILICON KTA1266-AT(Y,GR) |
| Q507 | BZ510069 | TCATC31980 | TRANSISTOR,SILICON KTC3198-AT(Y,GR) |
| Q601 | BZ510070 | TCAT032034 | TRANSISTOR,SILICON KTC3203_Y-AT |
| Q602 | BZ510070 | TCAT032034 | TRANSISTOR,SILICON KTC3203_Y-AT |
| Q603 | BZ510070 | TCAT032034 | TRANSISTOR,SILICON KTC3203_Y-AT |
| Q606 | BZ510070 | TCAT032034 | TRANSISTOR,SILICON KTC3203_Y-AT |
| Q607 | BZ510069 | TCATC31980 | TRANSISTOR,SILICON KTC3198-AT(Y,GR) |
| △Q801 | AD300794 | TCKT1473A0 | TRANSISTOR,SILICON 2SC1473A-TA-(RQ) |
| △Q802 | AD300794 | TCKT1473A0 | TRANSISTOR,SILICON 2SC1473A-TA-(RQ) |
| △Q803 | AD300794 | TCKT1473A0 | TRANSISTOR,SILICON 2SC1473A-TA-(RQ) |
| COILS & TRANSFORMERS | | | |
| L001 | AE000290 | 02167F3R3J | COIL 3.3 UH |
| L401 | AD301644 | 021L75472J | COIL 4.7 MH |
| △L501 | AE005719 | 0293000130 | COIL,LINE FILTER ELF15N010AP |
| △L503 | AE005718 | 028B140033 | COIL,DEGAUSS DYD1-3020-80 |
| L801 | BZ310113 | 021673221K | COIL 220 UH |
| T401 | BZ310157 | 045009003J | TRANS,HORIZONTAL DRIVE ETH09K14BZ |
| △T502 | AD302162 | 0481291084 | TRANSFORMER,SWITCHING 81291084 |
| JACKS | | | |
| J702 | AE005633 | 060Q401112 | RCA JACK AV1-09AD-3 |
| J703 | AE005632 | 060Q401111 | RCA JACK AV1-09AD-4 |
| △J801 | BZ614434 | 066F120018 | SOCKET,CATHODE RAY TUBE ISMS01S |
| △J1001 | AD302163 | 060J121014 | JACK,RCA,3.5 MSJ-035-12A_PC |
| SWITCHES | | | |
| SW101 | BZ612010 | 0504101T34 | SWITCH,TACT EVQ21505R |
| SW102 | BZ612010 | 0504101T34 | SWITCH,TACT EVQ21505R |
| SW103 | BZ612010 | 0504101T34 | SWITCH,TACT EVQ21505R |
| SW104 | BZ612010 | 0504101T34 | SWITCH,TACT EVQ21505R |
| SW105 | BZ612010 | 0504101T34 | SWITCH,TACT EVQ21505R |
| P.C.BOARD ASSEMBLIES | | | |
| PCB010 | AE007182 | A3M132X010 | PCB ASS'Y CMD009A |
| PCB110 | AE005725 | A3M131V110 | PCB ASS'Y CCD004A |
| MISCELLANEOUS | | | |
| B501 | BZ310121 | 024HT03553 | CORE,BEADS W5RH3.5X5X1.0 |
| B504 | BZ310121 | 024HT03553 | CORE,BEADS W5RH3.5X5X1.0 |
| BT001 | AE005640 | 141R004016 | BATTERY,MANGAN GR03X-SP2 |
| BT002 | AE005640 | 141R004016 | BATTERY,MANGAN GR03X-SP2 |
| △CD501 | AE005639 | 1209414909 | CORD,AC BUSH 9414909 |
| △CP401 | BZ614303 | 069S450089 | CONNECTOR PCB SIDE A1561WV2-A5P |
| △CP502 | BZ614283 | 069S420110 | CONNECTOR PCB SIDE A1561WV2-2P |
| CP503 | BZ614016 | 069W01001A | CONNECTOR PCB SIDE 003P-2100 |
| CP601 | AE005634 | 069S260639 | CONNECTOR PCB SIDE A2001WR2-6P |
| CP801 | AE007181 | 069W010340 | CONNECTOR PCB SIDE 131001101K1 |
| CD101A | AE005720 | 06C3012004 | CORD,CONNECTOR C3012004 |
| CD101B | AE005721 | 06C3012005 | CORD,CONNECTOR C3012005 |
| CP802A | BZ614276 | 067U005049 | WIRE HOLDER B2013H02-5P |
| CP802B | BZ614276 | 067U005049 | WIRE HOLDER B2013H02-5P |
| CP803A | BZ614334 | 067U004029 | WIRE HOLDER B2013H02-4P |
| CP803B | BZ614334 | 067U004029 | WIRE HOLDER B2013H02-4P |
| EL001 | BZ614043 | 124116281A | EYE LET XRY16X28BD |
| EL002 | BZ614044 | 124120301A | EYE LET XRY20X30BD |

ELECTRICAL REPLACEMENT PARTS LIST

| Location No. | TSB P/N | Reference No. | Description |
|--------------|----------|---------------|---------------------|
| △F501 | AD302166 | 081PC04005 | FUSE |
| △FB401 | AE003330 | 043214050F | TRANSFORMER,FLYBACK |
| FH501 | AE002634 | 06710T0009 | HOLDER,FUSE |
| FH502 | AE002634 | 06710T0009 | HOLDER,FUSE |
| OS101 | AD301048 | 0773071001 | REMOTE RECEIVER |
| S101 | AD302168 | WBL6026038 | FLAT CABLE |
| S102 | BZ614371 | WCL6834038 | FLAT CABLE |
| △SP1001 | AE005722 | 070Y132027 | SPEAKER |
| △TH501 | AD302000 | D8EE0B1400 | DEGAUSS ELEMENT |
| TM101 | AE003331 | 076N0EH050 | TRANSMITTER |
| △TU001 | AE006069 | 0163300018 | RF UNIT |
| △V801 | BZ614442 | 098Y1404C8 | CRT W/DY |
| X601 | BZ613004 | 100CT3R505 | CRYSTAL |

RESISTOR

RC..... CARBON RESISTOR

CAPACITORS

CC..... CERAMIC CAPACITOR
 CE..... ALUMI ELECTROLYTIC CAPACITOR
 CP..... POLYESTER CAPACITOR
 CPP..... POLYPROPYLENE CAPACITOR
 CPL..... PLASTIC CAPACITOR
 CMP..... METAL POLYESTER CAPACITOR
 CMPL..... METAL PLASTIC CAPACITOR
 CMPP..... METAL POLYPROPYLENE CAPACITOR

TOSHIBA CORPORATION

1-1, SHIBAURA 1-CHOME, MINATO-KU, TOKYO 105-8001, JAPAN